

News 2019

complements / beds





ITALIER

“ **KENDO**, è una famiglia di madie dal design brillante, razionale e tecnicamente raffinato. Kendo vuole suggerire con il suo design l'essenza della cultura giapponese in merito alle arti marziali e in particolare rispetto al culto della spada. Il concetto del “taglio” identifica chiaramente il focus della collezione, ossia una netta lacerazione di 30° sul frontale, dalla quale scaturiscono due ante “disassate” che sono cuore ed anima della collezione.

KENDO is a product family of sideboards that stands out for its brilliant, rational and technically sophisticated design. The Kendo design sets out to reflect the essence of Japanese culture in the ambit of the martial arts, with a particular reference to the sword cult. The “cut” concept clearly identifies the focus of the collection, in the form of a sharp 30° front cleft, producing two offset doors that are the heart and soul of the collection.

”

Meneghello Paoletti Associati



MENEGHELLO PAOLELLI ASSOCIATI

Product designers, consulenti strategici per il prodotto industriale, Sandro Meneghello e Marco Paoletti costituiscono Meneghello Paoletti Associati. Laureati nel 2004 al Politecnico di Milano, sotto la guida di Roberto Palomba e Paolo Rizzatto, dopo diverse esperienze internazionali - dalla Central Saint Martins di Londra e la Norwegian University of S&T di Trondheim, alla Köln Kisd University e EDF R&D di Parigi - fondano il loro studio a Milano. Dal 2005 si affiancano ad aziende italiane ed internazionali con il fine di creare valore aggiunto attraverso il design di prodotto. Hanno ricevuto numerosi riconoscimenti internazionali, tra cui cinque Red Dot Design Award, cinque Design Plus, due Good Design Award, un ADI Design Index, due menzioni speciali per il German Design Award e sei menzioni allo Young&Design.

As product designers and strategic consultants for industrial products, Sandro Meneghello and Marco Paoletti make up Meneghello Paoletti Associates. They graduated in 2004 from the Polytechnic university in Milan, under the guidance of Roberto Palomba and Paolo Rizzatto and, after various international experiences - from the Central Saint Martins University in London and the Norwegian University of Science & Technology in Trondheim, to the Köln International School of Design and EDF R&D in Paris - they founded their studio in Milan. Since 2005 they have been working alongside Italian and international companies with the aim of creating added value through product design. They have received numerous international awards, including five Red Dot Design Awards, five Design Plus awards, two Good Design Awards, one ADI Design Index award, two special mentions for the German Design Award and six Young&Design mentions.

KENDO / p. 40-43

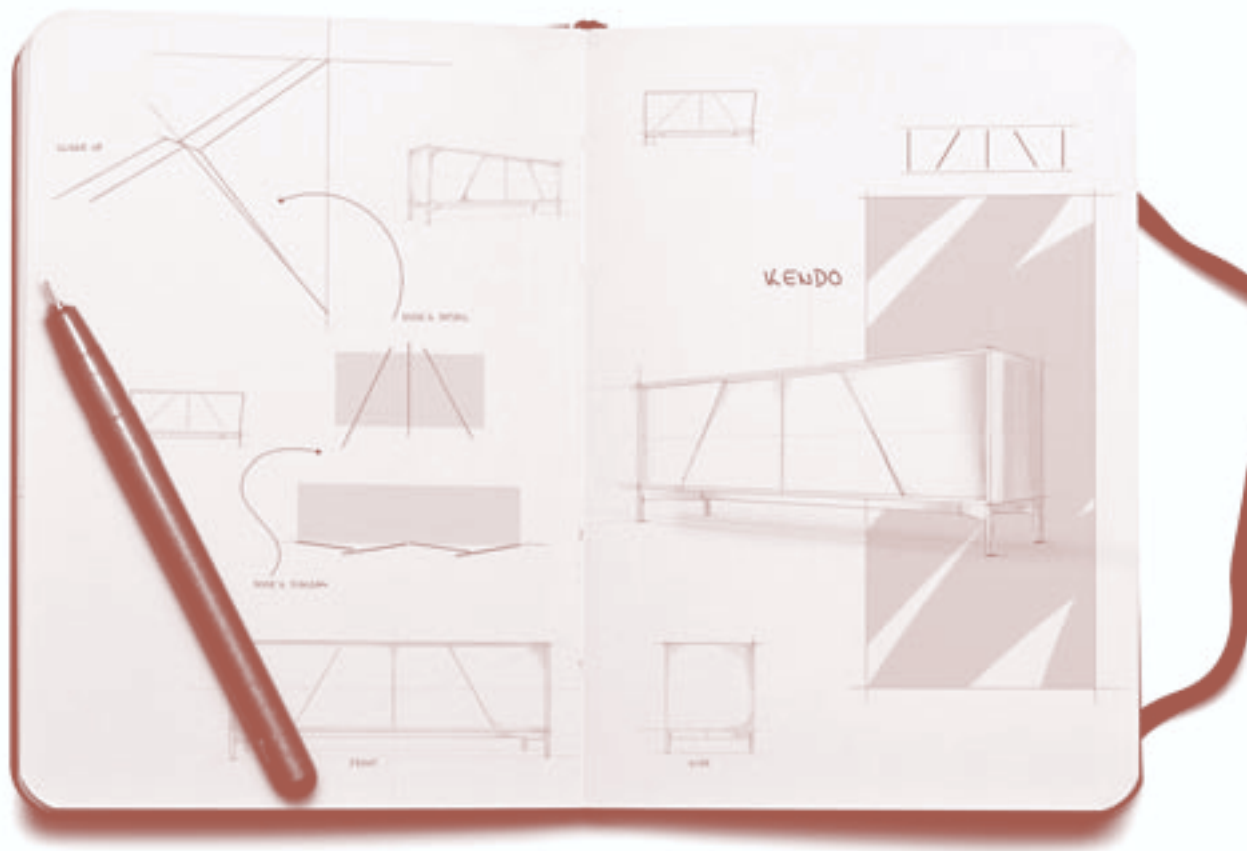
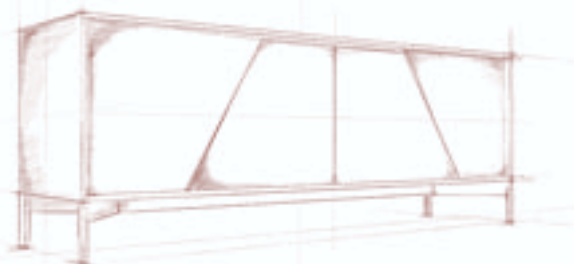
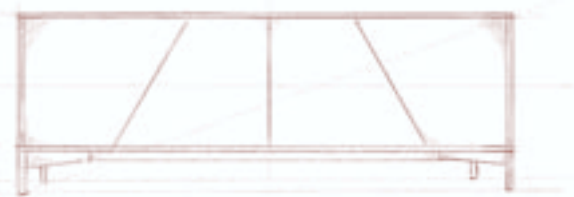

“ Per il letto NEYŌ ho pensato a delle forme morbide, consone al concetto dell'intimità sviluppandole attorno al tema della sospensione e leggerezza, assieme a quello materico per accentuare la dimensione tattile e visiva.

For the NEYŌ bed I thought of soft shapes, in keeping with the concept of intimacy, developing them around the theme of suspension, lightness and texture to accentuate the tactile and visual dimension.

Gordon Guillaumier

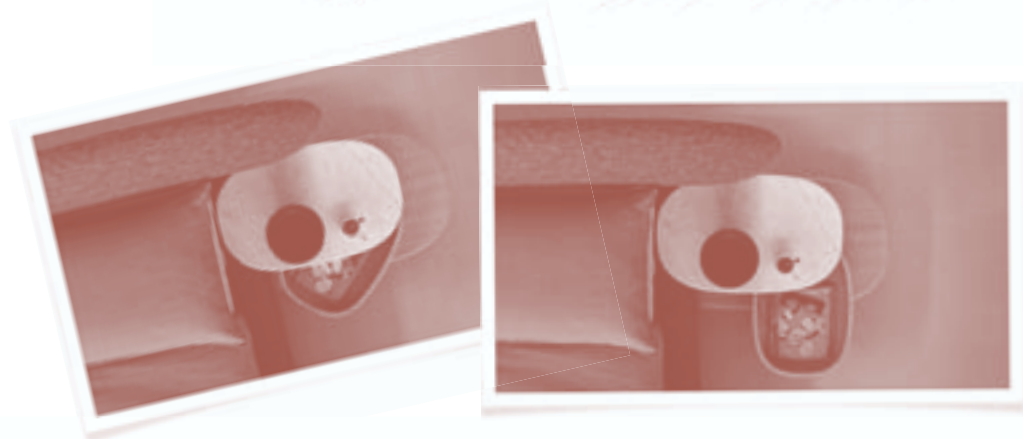

GORDON GUILLAUMIER

Gordon Guillaumier nasce nel 1966. Studia a Malta, in Svizzera, in Inghilterra e in Italia. Si diploma in industrial design presso lo IED di Milano (1988-1991) ottenendo successivamente un master in industrial design presso la Domus Academy, Milano (1992).

Nel 1993 dopo l'apprendistato presso Baleri Associati, collabora con Rodolfo Dordoni, disegnando i suoi primi pezzi. Nel 2002 apre il proprio studio, occupandosi di design consulting, product and interior design.

Ha collaborato con Azzurra Ceramiche, Bosa, Ceramiche Piemme, Desalto, DeSede, Driade, FontanaArte, Foscarini, Gebruder Thonet, Frag, Matteo Grassi, Minotti, Moroso, Oluce, Pamar, Paola C, Roda, Tacchini.

Tra i suoi vari riconoscimenti ricevuti sono: Interzum 2011 Award, Wallpaper Design Award 2014, Compasso d'Oro 2016.

Le sue opere di interior design e architettura, pubblicate dalle più prestigiose riviste e libri del settore, si concentrano principalmente su progetti residenziali privati. Ha insegnato presso la facoltà di design industriale del Politecnico di Milano e professore in visita all'Abadir Design Academy di Catania. La sua collaborazione per Alf DaFrè per cui firma numerosi progetti inizia nel 2017.

Gordon Guillaumier was born in 1966. He studied in Malta, Switzerland, England and Italy. He graduated from the IED in Milan in industrial design

(1988-1991) and then obtained a master's degree in industrial design from the Domus Academy, Milan (1992). In 1993, after his apprenticeship at Baleri Associati, he collaborated with Rodolfo Dordoni, designing his first pieces. In 2002, he opened his own studio where he offers product and interior design services and design consulting. He has collaborated with Azzurra Ceramiche, Bosa, Ceramiche Piemme, Desalto, DeSede, Driade, FontanaArte, Foscarini, Gebruder Thonet, Frag, Matteo Grassi, Minotti, Moroso, Oluce, Pamar, Paola C, Roda and Tacchini.

He has received various awards including the Interzum 2011 Award, the Wallpaper Design Award 2014, and the Compasso d'Oro 2016.

His interior design and architectural works, published in some of the most prestigious magazines and books in the field, mainly focus on private residential projects. He has taught at the Faculty of Industrial Design at Milan's Polytechnic university and is a visiting professor at the Abadir Design Academy in Catania. He began collaborating with Alf DaFrè in 2017 and has designed numerous projects.

RAKU / p. 14, 17, 23-29, 43, 46-55, 81, 91-92, 97,103

NEYŌ / p. 70-79, 82-83

“ RAKU è una collezione di sedute imbottite nata come estensione di Neyō. ho voluto dare un'anima unica a questa collezione che vive bene assieme o come singoli pezzi, sia per la zona notte sia per spazi giorno della casa e aree contract.

RAKU is a collection of upholstered chairs, created as an extension of Neyō. I wanted to give a unique feel to this collection that works well together or as single pieces, both in the bedroom, as well as in the living room and in larger business spaces.

Gordon Guillaumier

”

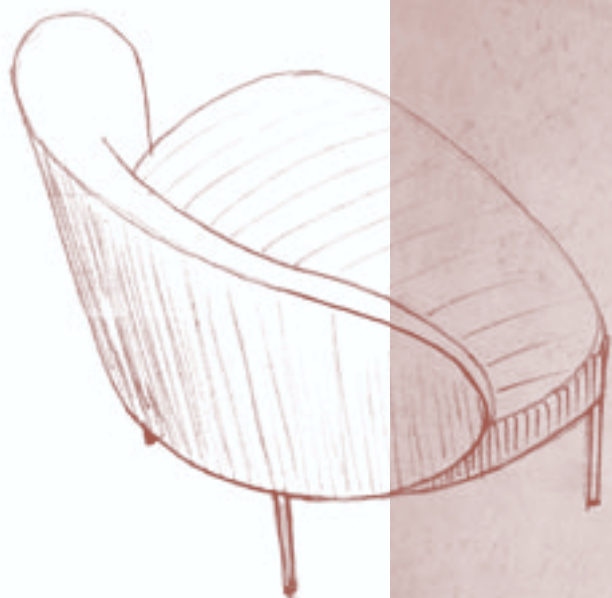



“ **CALIFORNIA** è un prodotto “storico” dell’azienda, pensato per integrarsi con i sistemi giorno aziendali; oggi è ripensato dal punto di vista funzionale per adattarsi alle nuove esigenze abitative. Nuove tipologie di seduta, nuove profondità, nuove funzioni permettono a California una contemporaneità senza tempo ed una capacità di adattarsi ad ogni spazio domestico.

CALIFORNIA is one of the company’s historic products, designed to integrate with its living room collections; today it has been reworked in terms of its function to adapt to new living requirements. New types of seat, new depths and new functions ensure California remains current and adaptable to any domestic space.

”

Enrico Cesana

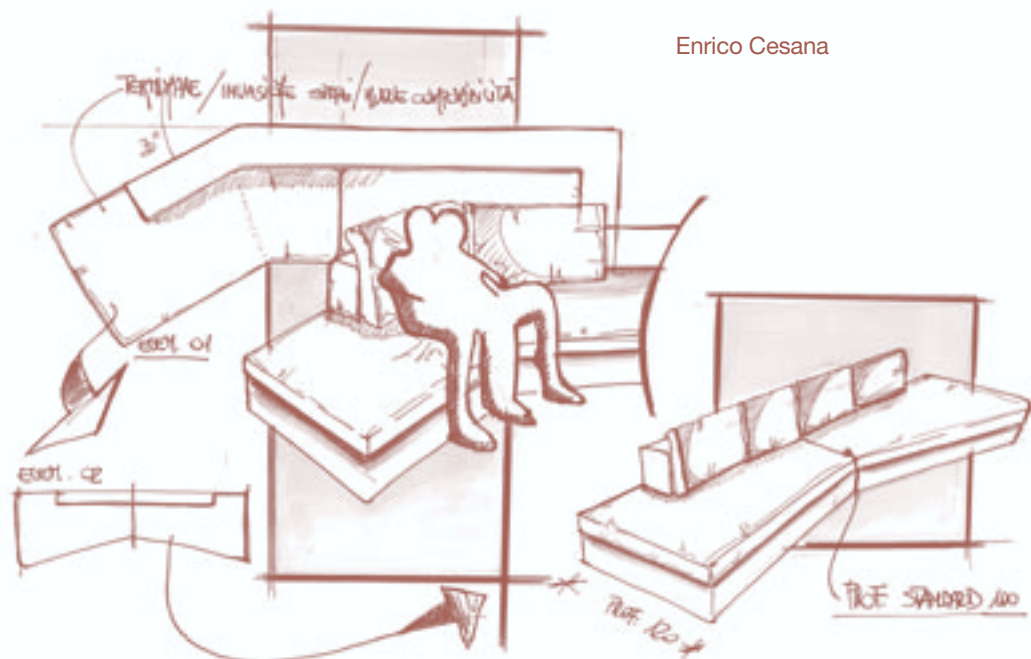

ENRICO CESANA

Enrico Cesana nasce nel 1970. Ha frequentato la facoltà di architettura al Politecnico di Milano dove si è laureato nel 1997. Dal 1998 al 2004 due esperienze professionali felici lo portano ad occuparsi di industrial ed interior design e ad approfondire metodi ed approcci progettuali diversi. Nel 2005 apre il proprio studio a Lissone (MB), occupandosi di industrial design, architettura e comunicazione; firma più di 100 prodotti per importanti realtà italiane – tra cui SpHaus, Ivano Redaelli, Gruppo Industriale Busnelli, Acam, Cinova, Orizzonti, Olivieri, Alivar, My Home collection, Dorelan e Alf DaFrè – e progetta i concept store per Corner Optique by Randazzo, Next People by Aureli, Optissimo Gruppo Randazzo, Samsonite e Cleaf Spa. Progettista versatile e prolifico, ama descriversi come un “designer al servizio delle aziende”.

Enrico Cesana was born in 1970. He attended the Faculty of Architecture at Milan’s Polytechnic university, where he graduated in 1997. Between 1998 and 2004, two enjoyable professional experiences led him to focus on industrial and interior design and to investigate various design methods and approaches. In 2005, he opened his own industrial design, architecture and communication studio in Lissone (MB); he has designed more than 100 products for leading Italian concerns, including SpHaus, Ivano Redaelli, Gruppo Industriale Busnelli, Acam, Cinova, Orizzonti, Olivieri, Alivar, My Home collection, Dorelan and Alf DaFrè, and has designed the concept stores for Corner Optique by Randazzo, Next People by Aureli, Optissimo Gruppo Randazzo, Samsonite and Cleaf Spa. He is a versatile and prolific designer, who loves to describe himself as a “designer catering to the needs of companies”.

NEVADA / p. 32-39
CALIFORNIA / p. 14-21
COPENAGHEN / p. 86-93

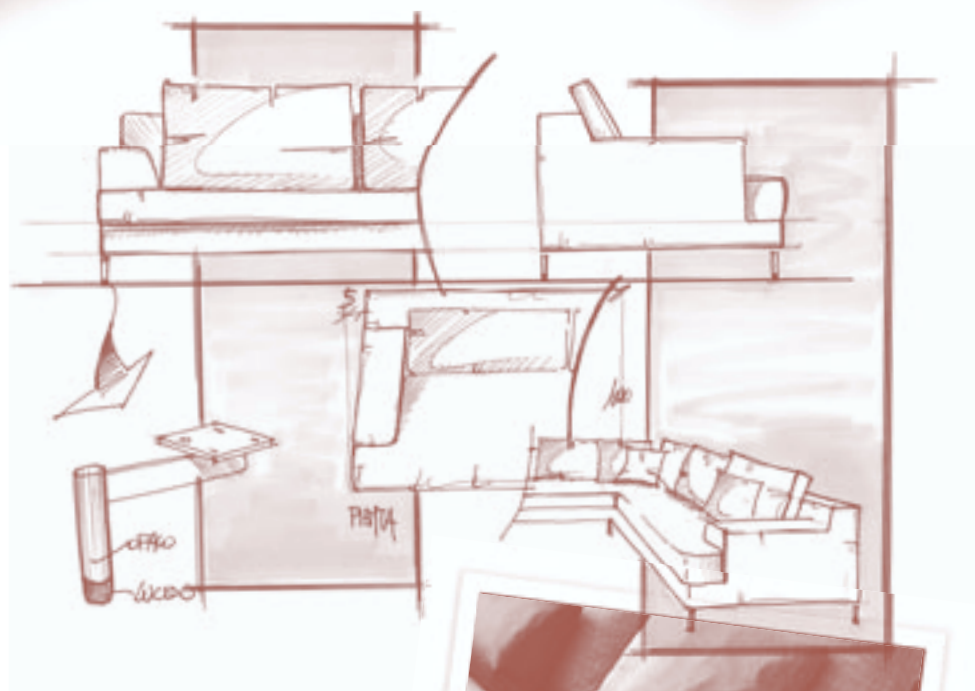

“ NEVADA è pensato per fare da trait d’union tra la tradizione e la contemporaneità. Le forme si fanno meno rigorose e più morbide ed accoglienti, l’immagine generale leggera è accentuata dal disegno essenziale ed aereo dei piedini in metallo. Molti elementi compositivi permettono di configurare la soluzione adatta per ogni abitazione.

NEVADA is designed to act as a link between tradition and modernity. The shapes are less rigorous, softer and more welcoming, and the overall lighter image is accentuated by the simple, airy design of the metal feet. Having lots of compositional pieces to work with means you can configure the right solution for each home. ”

Enrico Cesana

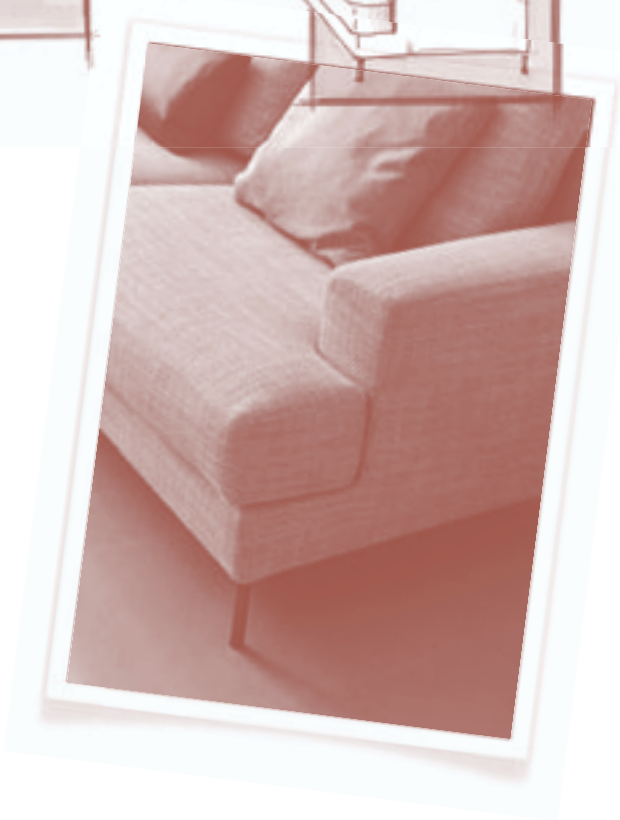

“ Una nuova profondità trasforma il concetto di living e permette di personalizzare ed adattare COPENAGHEN alle nuove esigenze di vita quotidiana. Il divano diventa il fulcro di molte attività quotidiane, studiare, leggere, lavorare, riposarsi e stare con gli amici, oggi tutto è possibile grazie al nuovo comfort ed alla nuova profondità maggiorata che permette di personalizzare ed adattare il prodotto alle esigenze di vita desiderate. Sedute lineari e sincere, ricche di contenuti sartoriali che valorizzano un patrimonio genetico aziendale fatto di ricerca ed artigianalità.

New depth transforms the living space concept and allows you to customise and adapt COPENAGHEN to the needs of everyday modern life. the sofa is the cornerstone of many daily activities: studying, reading, working, relaxing and spending time with friends. Today, anything is possible thanks to new comfort and increased depth, to customise and adapt the product to your everyday needs. Straightforward, linear seats, rich in sartorial details underline the company’s DNA made up of research and craftsmanship. ”

Enrico Cesana





BRUNA VACCHER

Inizia l'attività professionale nel 1990, dopo la laurea in architettura presso lo IUAV di Venezia e fonda lo studio Modacasa atelier architettura. Molteplici sono le esperienze nel campo dell'architettura, direzione artistica e design nel settore dell'arredamento.

She began her professional career in 1990, after graduating in Architecture from the IUAV in Venice, founding Modacasa, an architectural studio. She has a wealth of experience in the fields of architecture, artistic management and furniture design.

RELIEF / p. 14-27, 43, 58-59, 62-67, 70, 74, 77-78, 82, 86-93

“

Il segno grafico di questo tappeto è dato dal gioco di 2 tessiture diverse che combinate con l'effetto vibrante della viscosa e la lavorazione a mano eseguita negli antichi telai indiani, ne danno un sapore caldo e contemporaneo.



Two different weaves combine to give this rug its pattern. It has a warm yet contemporary feel thanks to the shimmering viscose and handcrafted detailing created on ancient Indian looms.

”

Bruna Vaccher





KIHONOS
LA MARCHÉ DES PESSOUS
ANTHONY MARRAS



CALIFORNIA divano / sofa
Tessuto Fado 26 / Fado 26 fabric
L356 P125 H84

MOCA tavolino / occasional table
Struttura laccato Nero opaco,
piano laccato micalizzato Oro /
Structure in matt Nero lacquered,
Top in Micalyzed Oro laquered
L60 P60 H45,4

WOK tavolino / occasional table
Laccato Nero opaco / Matt Nero
lacquered
L27,5 P27,5 H50

RAKU poltrona / armchair
Tessuto Nina 31 / Nina 31 fabric
L84 P69 H75

RAKU pouf
Tessuto Nina 31 / Nina 31 fabric
L67 P49 H41,5

CALIFORNIA

Divano / Sofa
design Enrico Cesana

Il divano CALIFORNIA si arricchisce con penisole e moduli che escono dalla logica dell'ortogonalità e creano sedute conviviali e adatte a un'idea di living meno schematica e formale, invece più aperta e accogliente.

The CALIFORNIA sofa features lounge end units and modules that go beyond the idea of square right angles. They create convivial seating arrangements suitable for a less schematic and formal idea of a living room that is more open and welcoming.

El sofá CALIFORNIA se completa con penínsulas y módulos que rompen con las reglas de la perpendicularidad y crean asientos para disfrutar en compañía, adaptados a un concepto de salón menos esquemático y formal, más abierto y acogedor.

Le canapé CALIFORNIA s'enrichit de péninsules et modules qui sortent de la logique de l'orthogonalité et créent des sièges conviviaux et adaptés à une idée de living moins schématique et formelle et plus ouverte et accueillante.

Das Sofa CALIFORNIA wird durch Liege-Inseln und Module ergänzt, die die rechtwinkelige Logik des Designs aufbrechen und Sitzflächen für ein gemütliches Zusammensein schaffen und ein offenes und freundliches Ambiente schaffen, das weniger schematisch und formal erscheint.

Диван CALIFORNIA дополнен полуостровными элементами и модулями, которые следуют логике прямоугольности и создают удобную для сидения мебель, подходящую для менее схематичной и формальной и в то же время – более открытой и уютной концепции гостиной.





CALIFORNIA divano / sofa
Pelle Lord 9120 / 9120 Lord
leather
L401,3 P147,2 H84

MOCA tavolino / occasional
table
Struttura laccato Nero opaco,
piano Fashion wood rovere
Fossile, laccato Nero opaco /
Structure in matt Nero
lacquered, Top in Fashion
wood Fossile oak, matt Nero
lacquered
L60 P60 H45,4
L90 P90 H37

WOK tavolino / occasional table
Laccato Nero opaco / Matt Nero
lacquered
L27,5 P27,5 H50

DENNY pouf
Pelle Lord 9120 / 9120 Lord
leather
L85 P85 H37

RAKU

Collezione di sedute / Seat collection
design Gordon Guillaumier

La collezione di sedute imbottite RAKU – che comprende poltrona + pouf, divanetto, sedia e panca – ha un’immagine contemporanea ed essenziale. Seduta e schienale sono definiti da volumi semplici e arrotondati. Il piede, altrettanto essenziale, è formato da un tubo verticale che sembra solo appoggiato all’esterno dei volumi. La panca imbottita prevede anche un bracciolo in legno che la divide trasversalmente creando un funzionale piano di appoggio. Disponibile con rivestimento in pelle e in tessuto, RAKU è perfetta per regalare un tocco di comfort alla zona giorno, come alla zona notte.

The RAKU collection of upholstered seats – which includes an armchair + footstool, small sofa, chair and bench – has a simple, contemporary look. The seat and back are defined by simple, rounded volumes. The equally simple leg is formed of a vertical bar that looks like it is resting against the outer edge of the chair back. The upholstered bench also has a wooden armrest that divides it widthways, creating a functional surface for resting things on. Available with leather and fabric upholstery, RAKU is perfect for adding a touch of comfort to the lounge and bedroom.

La colección de asientos tapizados RAKU – que abarca butaca + puff, sofá, silla y banqueta – ofrece una imagen moderna y sobria. El asiento y el respaldo están definidos por volúmenes simples y redondeados. Las patas, igualmente sencillas, están formadas por un tubo vertical que parece apoyarse simplemente por fuera de los volúmenes. La banqueta tapizada incluye también un reposabrazos de madera que la divide en sentido transversal, creando una superficie de apoyo funcional. Disponible con revestimiento de piel y de tejido, RAKU es perfecta para aportar un toque de confort a la zona de día, como en la zona de noche.

La collection de sièges rembourrés RAKU – qui comprend fauteuil + pouf, petit canapé, chaise et banquette – a une image contemporaine et essentielle. Assise et dossier sont définis par des volumes simples et arrondis. Le pied, tout autant essentiel, est formé par un tube vertical qui semble seulement posé à l’extérieur des volumes. La banquette rembourrée prévoit également un accoudoir en bois qui la divise transversalement en créant un plan d’appui fonctionnel. Disponible avec revêtement en cuir et en tissu, RAKU est parfait pour offrir une touche de confort à la zone jour, tout comme à la zone nuit.

Die Polstersitzkollektion RAKU steht mit ihren Sesseln + Polsterhockern, Sofas, Stühlen und Bänken für ein modernes und schlichtes Design. Sitz und Rückenlehne werden durch einfache und abgerundete Volumen definiert. Das ebenso schlicht gehaltene Bein besteht aus einem vertikalen Rohr, das auf der Außenseite der Volumen aufzuliegen scheint. Die gepolsterte Bank wird durch eine Armlehne aus Holz ergänzt, die sie quer unterteilt und so eine funktionale Auflagefläche schafft. RAKU ist mit Leder- und Stoffpolsterung erhältlich und eignet sich perfekt, um sowohl dem Wohn- als auch dem Schlafbereich einen Hauch von Komfort zu verleihen.

Коллекция мягкой мебели RAKU, включающая кресло + пуф, небольшой диван, стул и скамейку, отличается современной и строгой стилистикой без каких-либо излишеств. Сиденье и спинка обладают простыми и округлыми объемами. Ножки, также лишённые каких-либо излишеств, образованы вертикальными трубками, которые, как кажется, лишь слегка подпирают объёмы мебели снаружи. Мягкая скамейка имеет также деревянный подлокотник, который делит её поперек, создавая функциональную опорную поверхность. Предлагаемая в коже и ткани, коллекция RAKU идеально подходит для создания комфортной атмосферы как в гостиной, так и в спальне части дома.





FYRA tavolo / table
Fashion wood rovere Carbone /
Fashion wood Carbone oak
L200 P100 H75,4

RAKU sedia / chair
Pelle Lord 9120 / Lord 9120
leather
L55,5 P55 H80





RAKU divanetto / sofa
 Tessuto Regal E047 / Regal
 E047 fabric
 L158 P69 H75

MALMO tavolino / occasional
 table
 Struttura Moka Shine, Piano
 Fashion wood rovere Naturale
 / Structure in Moka Shine, Top
 in Fashion wood Naturale oak
 L42 P42 H50





RAKU poltrona / armchair
Tessuto Nina 6 / Nina 6 fabric
L84 P69 H75

NEYŌ tavolino / occasional
table
Struttura Moka Shine, Piano
Marmo Carrara / Moka Shine
structure, Top Carrara marble
L60 P38 H42







NEVADA

Divano / Sofa
design Enrico Cesana

NEVADA è un divano componibile che con la sua immagine sobria e informale esprime il perfetto equilibrio tra tradizione e contemporaneità. Le forme sono classiche ma la particolare geometria del bracciolo, la dimensione dei cuscini seduta, e l'essenzialità dei piedini in metallo rimandano definitivamente al gusto contemporaneo. La varietà dei moduli disponibili e la possibilità di rivestimento in tessuto e in pelle, rendono NEVADA un divano adatto agli spazi e agli stili più diversi.

NEVADA is a modular sofa that, with its simple, informal look, expresses a perfect balance between tradition and modernity. The shapes are classic but the unusual geometry of the armrests, the size of the seat cushions, and the simplicity of the metal feet definitely evoke a contemporary flavour. The variety of modules available and the fabric or leather upholstery make NEVADA a sofa that suits very different rooms and styles.

NEVADA es un sofá modular que, con su imagen sobria e informal, transmite el perfecto equilibrio entre tradición y modernidad. Sus formas son clásicas, pero la particular forma del reposabrazos, el tamaño de los cojines de asiento y la sencillez de las patas de metal evocan claramente un gusto moderno. La variedad de los módulos disponibles y la posibilidad de revestimiento de tejido o de piel hacen de NEVADA un sofá ideal para los espacios y estilos más diversos.

NEVADA est un canapé modulaire qui avec son image sobre et informelle exprime le parfait équilibre entre la tradition et la contemporanéité. Les formes sont classiques mais la géométrie particulière de l'accoudoir, la dimension des coussins de l'assise et l'essentiel des pieds en métal renvoient définitivement au goût contemporain. La variété des modules disponibles et la possibilité de revêtement en tissu et en cuir font de NEVADA un canapé adapté aux espaces et aux styles les plus divers.

NEVADA ist ein modulares Sofa, das mit seinem nüchternen und informellen Erscheinungsbild die perfekte Balance zwischen Tradition und Moderne herstellt. Die Formen sind klassisch, aber die besondere Form der Armlehne, die Größe der Sitzkissen und die Schlichtheit der Metallfüße setzen moderne Akzente. Die Vielfalt der verfügbaren Module und die Möglichkeit der Bespannung mit Stoff und Leder machen NEVADA zu einem Sofa, das sich für die unterschiedlichsten Räume und Stile eignet.

NEVADA – это модульный диван, который своим строгим и неформальным стилем выражает идеальное равновесие между традицией и современностью. У него классические формы, тем не менее, особая геометрия подлокотника, размер подушек для сидения и металлические ножки без каких-либо излишеств определенно несут в себе дух современности. Разнообразие предлагаемых модулей и возможность обивки тканью и кожей позволяют использовать диван NEVADA для самых разных по стилистике интерьеров.





NEVADA divano / sofa
Tessuto Fado 2 / Fado 2 fabric
L470,4 P285 H81,7

NEVADA pouf
Tessuto Dalì 04 / Dalì 04 fabric
L185 P86 H44

NEYŌ tavolino / occasional
table
Struttura Moka Shine, Piano
Mamo Carrara /
Structure Moka Shine, Top in
Carrara Marble
L60 P38 H42

DENNY pouf
Pelle Lord 9120 / 9120 Lord
leather
L85 P85 H37



NEVADA divano / sofa
Tessuto Fado 2 / Fado 2 fabric
L302 P146 H81,7

MOCA tavolino / occasional table
Struttura laccato Nero opaco,
piano Fashion wood rovere
Fossile /
Structure in matt Nero lacquered,
Top in Fashion wood Fossile oak
L90 P90 H37

NEVADA pouf
Tessuto Dali 04 / Dali 04 fabric
L185 P86 H44



KENDO

Credenza / Sideboard
design Meneghello Paoletti Associati

KENDO è una credenza caratterizzata da un particolare gioco geometrico delle ante: ciascuna anta presenta un taglio a 30° che la divide in due parti non perfettamente coplanari ma lievemente disassate, regalando alla superficie un raffinato effetto di chiaroscuro. KENDO è proposto nelle finiture nobilitate, Fashion wood e laccati. È eventualmente disponibile anche con ante, struttura e top in finiture o colore differenti.

KENDO is a sideboard with unusual geometric doors: each one has a 30° cut that divides it into two parts that are not on exactly the same plane but instead slightly off-centre, lending the surface a refined light and shade effect. KENDO is available in a surfaced, Fashion Wood or lacquered finish. It is also available with the doors, frame and top in different finishes or colours.

KENDO es un aparador caracterizado por un particular juego geométrico de las puertas: cada una de ellas presenta un corte a 30° que la divide en dos partes no perfectamente coplanares, sino levemente desalineadas, confiriendo a la superficie un elegante efecto de claroscuro. KENDO está disponible en los acabados ennoblecidos, Fashion wood y lacados. Bajo pedido, las puertas, la estructura y la encimera pueden tener acabados o colores diferentes.

KENDO est un bahut caractérisé par un jeu géométrique des portes particulier : chaque porte présente une découpe à 30° qui la divise en deux parties non parfaitement coplanaires mais légèrement désaxées, en offrant à la surface un raffiné effet de clair-obscur. KENDO est proposé dans les finitions mélaminés, Fashion wood et laquées. Éventuellement, il est également disponible avec portes, structure et plan dans des finitions et coloris différents.

KENDO ist ein Sideboard, das sich durch ein besonderes geometrisches Spiel auf der Front auszeichnet: Jede Tür hat einen 30°-Schnitt, der sie in zwei Teile teilt, die nicht perfekt komplanar, sondern leicht versetzt sind, wodurch auf der Oberfläche ein raffiniertes Spiel mit Licht und Schatten entsteht. KENDO ist erhältlich in den Ausführungen Melamin, Fashion Wood und lackiert. Türen, Korpus und Platten können zudem in unterschiedlichen Ausführungen oder Farben geliefert werden.

KENDO – это тумба с характерным геометрическим рисунком дверей: каждая с 30-градусным наклонным разрезом, разделяющим ее на две части, которые не идеально лежат в одной плоскости, а слегка смещены, что придает их поверхности изысканный светотеневой рисунок. KENDO предлагается в ламинированных отделках, Fashion wood и крашеных. Она также предлагается с дверцами, корпусом и столешницей в различных отделках или цветах.





KENDO credenza / sideboard
 Struttura Fashion wood rovere
 Fossile, ante laccato lucido
 Modica / Fashion wood Fossile
 oak structure, doors in high
 gloss Modica laquered
 L210 P50 H78

FYRA tavolo / table
 Fashion wood rovere Carbone /
 Fashion wood Carbone oak
 L200 P100 H75,4

RAKU sedia / chair
 Pelle Lord 9120 / Lord 9120
 leather
 L55,5 P55 H80

ESAGONA specchiera / mirror
 Cornice Moka Shine / Moka
 Shine frame
 L80 P5 H69,3







RAKU divanetto / sofa
Tessuto Regal E003 / Regal
E003 fabric
L158 P69 H75

RAKU poltrona / armchair
Tessuto Nina 28 / Nina 28
fabric
L84 P69 H75



RAKU divanetto / sofa
 Tessuto Regal E048 / Regal
 E048 fabric
 L158 P69 H75





RAKU panca con bracciolo /
bench with armrest
Tessuto Regal E048, bracciolo
Fashion wood rovere Naturale
/ Regal E048 fabric, Armrest in
Fashion wood Naturale oak
L150 P68 H53





RAKU divanetto / sofa
Tessuto Regal E038 / Regal
E038 fabric
L158 P69 H75

RAKU poltrona / armchair
Tessuto Nina 4 / Nina 4 fabric
L84 P69 H75





RAKU poltrona / armchair
Tessuto Nina 23 / Nina 23 fabric
L84 P69 H75

NEYŌ tavolino / occasional
table
Struttura Moka Shine, Piano
Marmo Carrara / Moka Shine
structure, Top Carrara marble
L60 P38 H42







FYRA

Tavolo / Table

Il tavolo è caratterizzato da geometrie sofisticate e da “stacchi” tra gli elementi che rendono la composizione molto espressiva. Il piano, definito da una linea mista a metà tra retta e curvilinea, è diviso in 4 quadranti che creano con le venature del legno un motivo tipico della tradizione ebanista. Una piastra di ferro collega e contemporaneamente separa visivamente il piano dalle 4 gambe a sezione conica irregolare, più rotonda alla base e più ovalizzata all’estremità superiore. FYRA è proposto in tutte le finiture di Fashion wood e roveri laccati.

The table features sophisticated geometry and intervals between the elements that make the composition very expressive. The top, defined by a line that is a mixture of half straight and half curvilinear, is divided into 4 quarters which create a typical design from traditional carpentry with the wood grain. An iron plate connects and, at the same time, visually separates the top from the 4 legs which have an irregular conical cross-section, rounder at the base and more oval at the top end. FYRA comes in all the Fashion Wood and matt lacquered oak finishes.

La mesa se caracteriza por formas sofisticadas y por “separaciones” entre los elementos, que otorgan una gran expresividad a la composición. El sobre, definido por una línea mixta a mitad de camino entre recta y curva, está dividido en 4 cuadrantes que, con las vetas de la madera, crean un motivo típico de la tradición ebanista. Una placa de hierro une y separa visualmente al mismo tiempo el sobre y las 4 patas de sección cónica irregular, más redonda en la parte inferior y más ovalada en el extremo superior. FYRA está disponible en todos los acabados de Fashion wood y roble lacados mate.

La table est caractérisée par des géométries sophistiquées et par des contrastes entre les éléments qui rendent a composition très expressive. Le plateau, défini par une ligne mixte à moitié entre droite et incurvée, est divisé en 4 cadrans qui créent avec les veinures du bois un motif typique de la tradition ébéniste. Une plaque de fer relie et en même temps sépare visuellement le plateau des 4 pieds à section conique irrégulière, plus ronde à la base et plus ovalisée à l'extrémité supérieure. FYRA est proposée dans toutes les finitions de Fashion wood et chêne laqués mats.

Der Tisch zeichnet sich durch raffinierte Formen und „Brüche“ zwischen den Elementen aus, die der Komposition einen starken Charakter verleihen. Die Platte hat einen Schwung, spielt mit geraden und abgerundeten Linien spielt, und ist in 4 Elemente unterteilt, deren Maserung ein klassisches Motiv aus der Tischlerei ergibt. Eine Eisenplatte verbindet und trennt gleichzeitig die Tischplatte von den 4 kegelförmigen Beinen, die sich nach unten hin verjüngen. FYRA ist in allen Ausführungen von Fashion Wood und Eiche matt lackiert erhältlich.

Стол характеризуется сложной геометрией и «контрастами» между элементами, которые делают композицию очень выразительной. Поверхность столешницы, определяемая комбинированной линией – наполовину прямой, наполовину кривой, разделена на 4 квадрата, которые создают вместе с текстурой дерева типичный для мебельной традиции рисунок. Металлическая пластина соединяет и в то же время визуальнo отделяет столешницу от 4 ножек с неравномерным коническим сечением, более круглым в основании и более овальным в верхней части. FYRA предлагается во всех отделках Fashion wood и Дуб крашенный матовый.





FYRA tavolo / table
Fashion wood rovere Naturale /
Fashion wood Naturale oak
L278,5 P104,5 H75,4

CORIUM sedia / chair
Tessuto Fado 26 / Fado 26
fabric
L50,5 P55 H80





FYRA tavolo / table
 Fashion wood rovere Naturale /
 Fashion wood Naturale oak
 L278,5 P104,5 H75,4

CORIUM sedia / chair
 Tessuto Fado 26 / Fado 26
 fabric
 L50,5 P55 H80

RELIEF

Collezioni tappeti / Rugs collection
design Bruna Vaccher

Le proprietà brillanti della viscosa di bamboo sono utilizzate al meglio in questo esercizio di tessitura manuale contemporanea.

Il volume di questa tessitura, ottenuto dai telai antichi ancora disponibili in India, risulta essere compatto, seducente e vibrante alla luce.

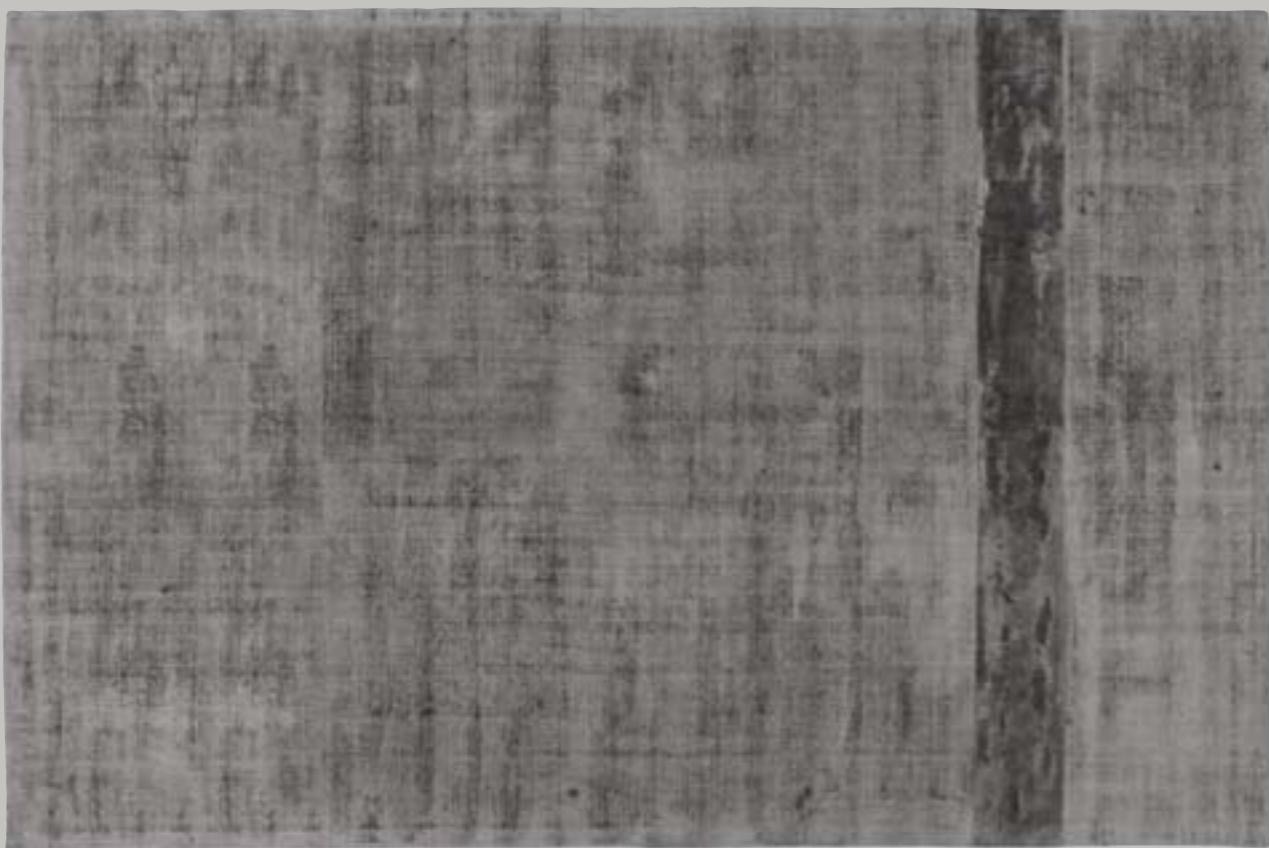

The shiny properties of bamboo viscose can be fully appreciated in this contemporary manual weave. Created using ancient looms still found in India, this weave is compact, seductive and glimmers in the light.

Las propiedades brillantes de la viscosa de bambú se aprovechan al máximo en este tejido de elaboración manual y moderna. El volumen de este tejido, logrado mediante antiguos telares aún disponibles en la India, resulta compacto, cautivador y vibrante a la luz.

Les propriétés brillantes de la viscosse de bambou sont utilisées au mieux dans cet exercice de tissage manuel contemporain. Le volume de ce tissage, obtenu à partir de métiers à tisser antiques encore disponibles en Inde, s'avère être compact, séduisant et vibrant à la lumière.

Die brillanten Eigenschaften von Bambusviskose kommen bei diesem handgewebten modernen Teppich bestens zur Geltung. Dieses Produkt entsteht auf alten, noch in Indien eingesetzten Webstühlen und überzeugt durch eine kompakte Webart, die verführerisch und lebendig mit dem Licht spielt.

Превосходные характеристики бамбуковой вискозы наилучшим образом выражены в этом образце современного ручного прядения. Объем такого прядения, достигаемый на античных станках, до сих пор используемых в Индии, является компактным, обольстительным и вибрирующим на свет.





La linea del letto NEYŌ si ispira alla forma organica dei ciottoli di fiume levigati dall'acqua. Il disegno morbido che definisce sia gli elementi imbottiti sia i doppi ripiani regala alla composizione l'aria avvolgente e funzionale di un letto a cui non servono altri complementi. Il letto può essere rivestito con tutti i tessuti e le pelli disponibili in catalogo, i ripiani laterali sono proposti in Fashion wood, roveri laccati opachi o marmo di Carrara.

The line of the NEYŌ bed is inspired by the organic shape of pebbles washed smooth by the flow of a river. The soft design of both the padded elements and the double shelf adds a welcoming, functional air to the composition. This bed needs no further complements. It can be upholstered in all the fabrics and leathers available in the catalogue, while the side shelves are available in Fashion Wood, matt lacquered oak or Carrara marble.

La línea de la cama NEYŌ se inspira en la forma orgánica de los cantos rodados de río, pulidos por el agua. El suave dibujo que define tanto los elementos tapizados como las dobles baldas infunde a la composición el aspecto envolvente y funcional de una cama que no necesita más complementos. La cama se puede revestir con todos los tejidos y pieles disponibles en el catálogo. Las baldas laterales están disponibles en Fashion wood, robles lacados mate o mármol de Carrara.

La ligne du lit NEYŌ s'inspire de la forme organique des galets de fleuve polis par l'eau. Le doux dessin qui définit aussi bien les éléments rembourrés que les doubles étagères offre à la composition l'aspect enveloppant et fonctionnel d'un lit qui n'a pas besoin d'autres compléments. Le lit peut être revêtu avec tous les tissus et les cuirs disponibles dans le catalogue. Les étagères latérales sont proposées en Fashion wood, chênes laqués mats ou marbre de Carrara.

Die Linie des Bettes NEYŌ ist inspiriert von der organischen Form der Flusskiesel mit ihrer vom Wasser geglätteten Oberfläche. Das weiche Design, das sowohl die Polsterelemente als auch die beiden Ablageflächen definiert, verleiht der Komposition eine einladende und doch funktionale Ausstrahlung eines Bettes, das kein weiteres Zubehör benötigt. Das Bett kann mit allen im Katalog erhältlichen Stoffen und Ledern bezogen werden. Die seitlichen Ablagen sind in Fashion Wood, Eiche matt lackiert oder Carrara-Marmor erhältlich.

Линии кровати NEYŌ вдохновлены органичной формой сглаженной водой речной гальки. Мягкий дизайн, который определяет как мягкие элементы кровати, так и двойные полки, придает всей композиции чарующий и функциональный вид, которой не нужны другие аксессуары. Кровать может быть отделана любыми тканями и кожей, представленными в каталоге. Боковые полки предлагаются из Fashion wood, матового крашеного дуба или мрамора Carrara.





NEYÖ letto / bed
Comodino con doppia
mensola / Night stand with
double shelf
Tessuto Trento 05, Fashion
wood rovere Naturale,
Marmo Carrara /
Trento 05 fabric, Fashion
wood Naturale oak, Carrara
marble
L315,5 P220,3 H92,5



NEYÓ letto / bed
Comodino con cassetto rotante
/ Night stand with turning chest
Tessuto Trento 05, Fashion
wood rovere Naturale, Marmo
Carrara /
Trento 05 fabric, Fashion wood
Naturale oak, Carrara marble
L315,5 P220,3 H92,5





NEYŌ letto / bed
 Comodino con doppia
 mensola / Night stand with
 double shelf
 Tessuto Trento 05, Fashion
 wood rovere Naturale,
 Marmo Carrara /
 Trento 05 fabric, Fashion
 wood Naturale oak, Carrara
 marble
 L315,5 P220,3 H92,5

NEYŌ

Tavolino / Coffee table
design Gordon Guillaumier

Complemento ideale sia per la zona giorno che per la camera da letto il tavolino NEYŌ è caratterizzato dalla struttura in metallo finitura Moka Shine e il piano dalla linea curva disponibile nelle varianti Fashion wood, rovere laccati opachi o marmo di Carrara.

The ideal complement for both the living area and the bedroom, the NEYŌ occasional table has a metal frame in the Moka Shine finish and a curved top available in Fashion Wood, matt lacquered oak or Carrara marble.

Complemento ideal tanto para la zona de día como para el dormitorio, la mesita NEYŌ se caracteriza por su estructura de metal en acabado Moka Shine y su sobre de línea curva disponible en las variantes Fashion wood, roble lacados mate o mármol de Carrara.

Complément idéal aussi bien pour la zone jour que pour la chambre à coucher, la table basse NEYŌ est caractérisée par la structure en métal finition Moka Shine et le plateau à la ligne arrondie disponible dans les versions Fashion wood, chênes laqués mats ou marbre de Carrara.

Der NEYŌ Couchtisch ist die ideale Ergänzung für den Wohn- und Schlafbereich und zeichnet sich durch die das Metallgestell in der Ausführung Moka Shine und die geschwungene Platte in Fashion Wood, Eiche matt lackiert oder Carrara-Marmor aus.

Столик NEYŌ, идеально подходящий как для гостиной, так и для спальни, характеризуется металлической структурой в отделке Moka Shine и столешницей с изогнутыми линиями. Он предлагается из Fashion wood, матового крашеного дуба или мрамора Carrara.





NEYÖ letto / bed
Tessuto Trento 05 / Trento 05
fabric
L237,7 P220,3 H92,5

NEYÖ tavolino / coffee table
Struttura Moka Shine, Piano
Marmo Carrara /
Moka Shine structure, Top in
Carrara marble
L60 P38 H42







COPENAGHEN

Divano / Sofa
design Enrico Cesana

In aggiunta alle diverse varianti in catalogo, il divano COPENAGHEN è presentato oggi con una nuova profondità di 110 cm pensata per offrire una seduta più confortevole e idonea al relax in tutte le ore del giorno.

In addition to the different varieties in the catalogue, the COPENAGHEN sofa now comes in a new depth of 110 cm designed to provide a more comfortable seat suitable for relaxing at all times of the day.

Además de las diversas variantes del catálogo, el sofá COPENAGHEN está disponible ahora con una nueva profundidad de 110 cm pensada para ofrecer un asiento más cómodo e ideal para el relax a cualquier hora del día.

En plus des différentes variantes du catalogue, le canapé COPENAGHEN est aujourd'hui présenté avec une nouvelle profondeur de 110 cm conçue pour offrir une assise plus confortable et adaptée au relax à toutes les heures de la journée.

Zusätzlich zu den Katalogvarianten ist das Sofa COPENAGHEN nun auch mit einer neuen Tiefe von 110 cm erhältlich, die für eine komfortablere Sitzfläche sorgt und zu jeder Tageszeit zum Entspannen einlädt.

В дополнение к различным версиям в каталоге, диван COPENAGHEN предлагается сегодня с новой глубиной 110 см, специально предусмотренной для того, чтобы предложить более удобный диван, подходящий для расслабления и отдыха в любое время суток.





COPENAGHEN divano / sofa
Tessuto Rubens 06 / Rubens
06 fabric
L390 P110 H86

COPENAGHEN divano / sofa
Tessuto St. Moritz 041 / St.
Moritz 041 fabric
L255 P90 H86

MALMO tavolino / occasional
table
Struttura Moka Shine, Piano
Fashion wood rovere Naturale /
Structure in Moka Shine, Top in
Fashion wood Naturale oak
L42 P42 H50
Struttura Moka Shine, Piano
Fashion wood rovere Ghiro /
Structure in Moka Shine, Top in
Fashion wood Ghiro oak
L100 P100 H41,3
Struttura Laccato opaco
Origano, Piano Laccato lucido
Origano / Structure in matt
lacquered Origano, Top in high
gloss lacquered Origano
Struttura Laccato opaco Tè
verde, Piano Rovere colore
opaco Tè verde / Structure in
Matt lacquered Tè verde, Top in
Matt oak colour Tè verde
L150 P50 H54,2

RAKU divanetto / sofa
Tessuto Regal E047 / Regal
E047 fabric
L158 P69 H75







JETTY

Letto / Bed
design Gordon Guillaumier

Il letto JETTY, caratterizzato dalla struttura in metallo tubolare finitura elettrocol, oggi viene integrato dalla versione con testiera in tessuto.

The JETTY bed with a tubular metal frame in an Elettrocol finish is now complemented by a version with a fabric headboard.

La cama JETTY, caracterizada por su estructura de metal tubular en acabado elettrocol, se completa ahora con la versión que incluye cabecera en tejido.

Le lit JETTY, caractérisé par la structure en métal tubulaire finition elettrocol, est aujourd'hui intégré par la version avec tête de lit en tissu.

Das Bett JETTY, das sich durch das Gestell aus Metallrohr in Elettrocol auszeichnet, wird nun durch die Version mit Stoff-Kopfteil ergänzt.

Кровать JETTY, характеризуемая металлическим трубчатым каркасом с отделкой elettrocol, теперь предлагается в новом варианте с тканевой головной спинкой.





JETTY letto / bed
 Testiera tessuto Doble 02,
 Struttura verniciato Elettrocol /
 Headboard in Doble 02 fabric,
 Structure in Elettrocol painted
 L174 P212,6 H94,5

FIL gruppo notte / bedgroup
 Laccato opaco Platino / Matt
 Platino lacquered
 L90 P48 H49,6

ESAGONA specchiera / mirror
 Cornice Moka Shine / Moka
 Shine frame
 L80 P5 H69,3

ESAGONA / DISCO

Specchiere / Mirrors

Le specchiere ESAGONA e DISCO, adatte ad ogni ambiente, hanno cornice in metallo finitura Moka Shine. Il modello DISCO è disponibile in tre misure.

The mirrors ESAGONA and DISCO, suitable for any space, have a metal frame finished in Moka Shine. The DISCO model comes in three sizes.

Los espejos ESAGONA y DISCO, perfectos para cualquier espacio, tienen perfil de metal en acabado Moka Shine. El modelo DISCO está disponible en tres tamaños.

Les miroirs ESAGONA et DISCO, adaptés à tout espace ambiant, ont un cadre en métal finition Moka Shine. Le modèle DISCO est disponible en trois dimensions.

Die Spiegel ESAGONA und DISCO, die sich in jedem Ambiente zuhause fühlen, haben über einen Metallrahmen in Moka Shine. Das Modell DISCO ist in drei Größen erhältlich.

Зеркала ESAGONA и DISCO, подходящие для любой обстановки, имеют металлическую раму с отделкой Moka Shine. Модель DISCO предлагается трех размеров.

RAKU panca con bracciolo / bench with armrest
Tessuto Regal 48, bracciolo Fashion wood rovere Naturale / Regal 48 fabric, Armrest in Fashion wood Naturale oak
L150 P68 H53

DISCO specchiera / mirror
Cornice Moka Shine / Moka Shine frame
L76,5 P5,5 H76,5
L50 P50 H76,5

Raku

design **Gordon Guillaumier**



Materiali e finiture

Rivestimento:
Tessuti / Pelle / Ecopelle
Gambe in metallo:
Verniciato Moka Shine

Materials and finishes

Covering:
Fabric / Leather / Ecoleather
Metal legs:
Painted Moka Shine

Materiales y acabados

Revestimiento:
Tejidos / Piel / Eco-piel
Patas de metal:
Barnizado Moka Shine

Matériaux et finitions

Revêtement :
Tissus / Cuir / Éco-cuir
Pieds en métal :
Verni Moka Shine

Materialien und Ausführungen

Bezug:
Stoff / Leder / Kunstleder
Beinen aus Metall:
Lackiert Moka Shine

Материалы и варианты отделки

Обивка:
Ткань / Кожа / Экокожа
Металлические ножки:
Крашенный Moka Shine

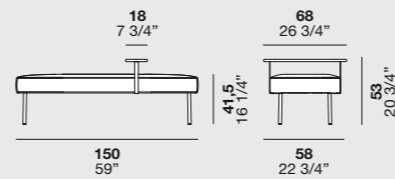
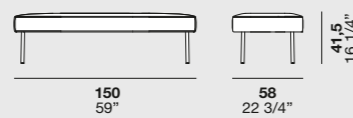
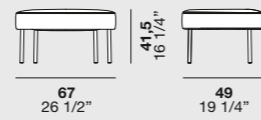
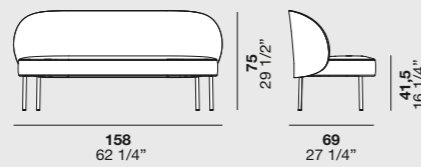
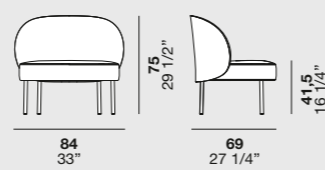
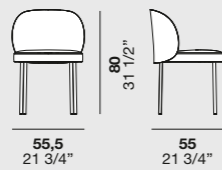

Corium

design **R.D.A.**



Materiali e finiture

Rivestimento:
Tessuti / Pelle / Ecopelle

Materials and finishes

Covering:
Fabric / Leather / Ecoleather

Materiales y acabados

Revestimiento:
Tejidos / Piel / Eco-piel

Matériaux et finitions

Revêtement :
Tissus / Cuir / Éco-cuir

Materialien und Ausführungen

Bezug:
Stoff / Leder / Kunstleder

Материалы и варианты отделки

Обивка:
Ткань / Кожа / Экокожа

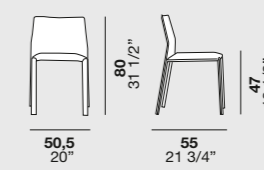
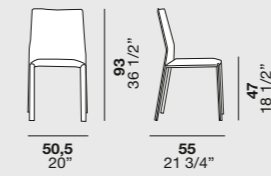

Kendo

design **Meneghello Paoletti Associati**



Materiali e finiture

Basamento in metallo:
verniciato Moka Shine
Struttura e frontali:
Nobilitati / Fashion wood / Rovere laccati opachi /
Laccati opachi e lucidi / Laccati micalizzati

Materials and finishes

Metal base:
Painted Moka Shine
Framework and fronts:
Surfaced / Fashion Wood / Matt lacquered oak
Matt and high-gloss lacquers / Micalised lacquereds

Materiales y acabados

Base de metal:
barnizado Moka Shine
Estructura y frontales:
Ennoblecidos / Fashion wood / Roble lacados mate
Lacados mate y brillantes / Lacados micalizada

Matériaux et finitions

Piètement en métal :
verni Moka Shine
Structure et façades :
Mélaminés / Fashion wood / Chêne laqués mats
Laqués mats et brillants / Laqués micalisée

Materialien und Ausführungen

Untergestell aus Metall:
lackiert Moka Shine
Korpus und Fronten:
Melamin / Fashion Wood / Eiche matt lackiert
Glänzend und matt lackiert / Mischbarer Lackiert

Материалы и варианты отделки

Металлическое основание:
крашеный Moka Shine
Каркас и фронтальные панели:
Ламинированный / Fashion wood / Дуб крашеный
матовый / Крашеный матовый и глянцевый
/ Микализированный лак

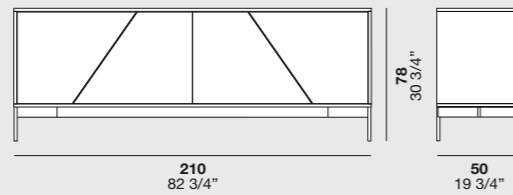
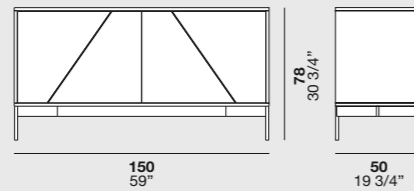

Disco

design **R.D.A.**

Materiali e finiture

Cornice metallo: Verniciato Moka Shine

Materials and finishes

Metal frame: Painted Moka Shine

Materiales y acabados

Perfil de metal: Barnizado Moka Shine

Matériaux et finitions

Cadre en métal : Verni Moka Shine

Materialien und Ausführungen

Metallrahmen: Lackiert Moka Shine

Материалы и варианты отделки

Металлическая рама: Крашеный Moka Shine

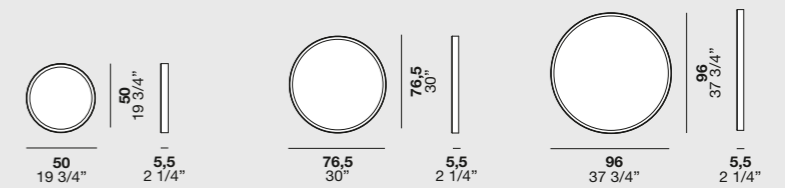

Esagona

design **R.D.A.**

Materiali e finiture

Cornice metallo: Verniciato Moka Shine

Materials and finishes

Metal frame: Painted Moka Shine

Materiales y acabados

Perfil de metal: Barnizado Moka Shine

Matériaux et finitions

Cadre en métal : Verni Moka Shine

Materialien und Ausführungen

Metallrahmen: Lackiert Moka Shine

Материалы и варианты отделки

Металлическая рама: Крашеный Moka Shine

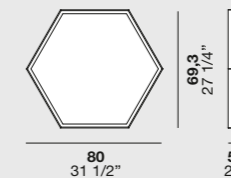

Nevada

design **Enrico Cesana**

Materiali e finiture

Rivestimento:
Tessuti / Pelle / Ecopelle
Gambe in metallo:
Verniciato Moka Shine

Materials and finishes

Covering:
Fabric / Leather / Ecoleather
Metal legs:
Painted Moka Shine

Materiales y acabados

Revestimiento:
Tejidos / Piel / Eco-piel
Patas de metal:
Barnizado Moka Shine

Matériaux et finitions

Revêtement :
Tissus / Cuir / Éco-cuir
Pieds en métal :
Verni Moka Shine

Materialien und Ausführungen

Bezug:
Stoff / Leder / Kunstleder
Beinen aus Metall:
Lackiert Moka Shine

Материалы и варианты отделки

Обивка:
Ткань / Кожа / Экокожа
Металлические ножки:
Крашенный Moka Shine

Divani

Sofas / Sofás / Canapés / Sofas / Диваны

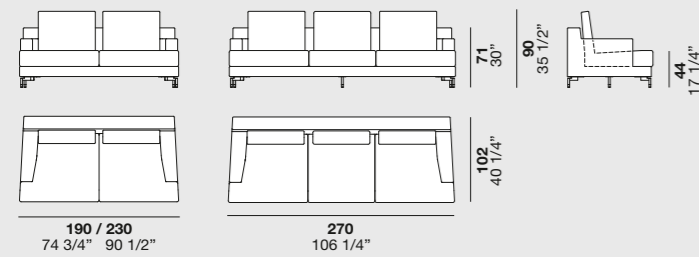

Moduli terminali sx o dx

Left or Right facing end units / Módulos terminales izda. o dcha. / Modules terminaux gauches ou droits / Abschlusselemente li. oder re. / Терминальные лев. или прав. модули

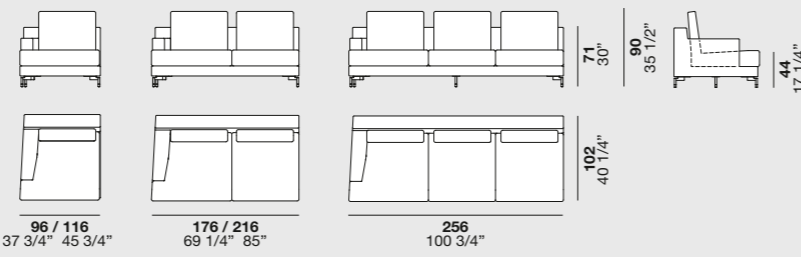

Moduli centrali

Central units / Módulos centrales / Modules centraux / Mittelelemente / Центральные модули

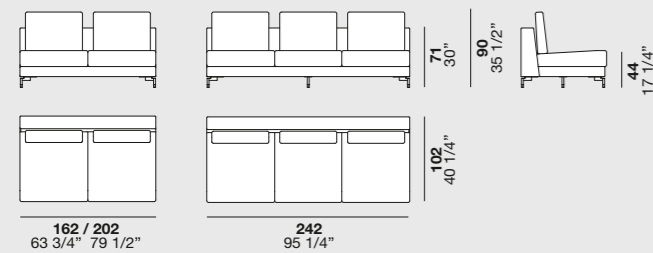

Angoli

Corner units / Módulos de esquina / Angles / Eckelemente / Угловые модули

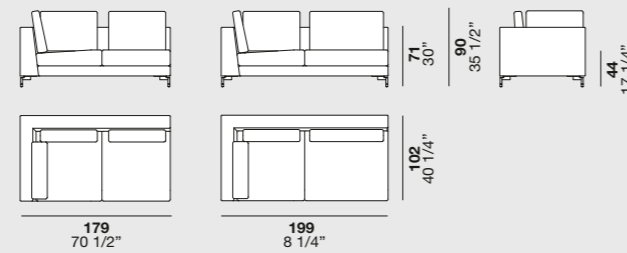

Moduli penisola

Peninsula units / Módulos península / Modules péninsule / Halbinsel-Module / Полуостровные модули

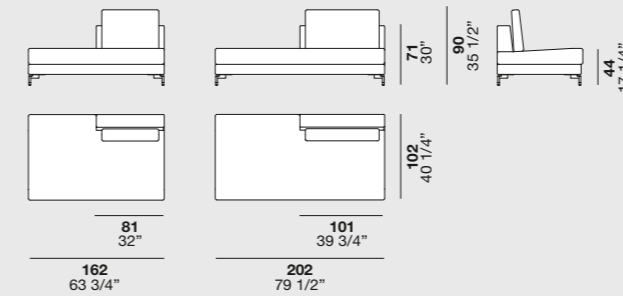

Moduli penisola inclinata

Angled lounge units / Módulos península inclinada / Modules péninsule inclinée / Module schräge Liege-Insel / Полуостровные наклонные модули

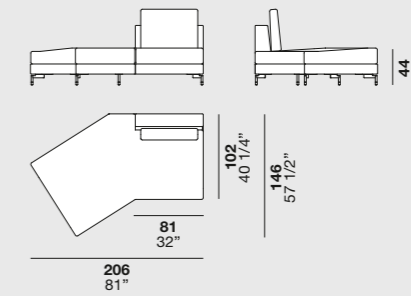

Pouf

Pouf / Puffs / Pouf / Polsterhocker / Пуфы

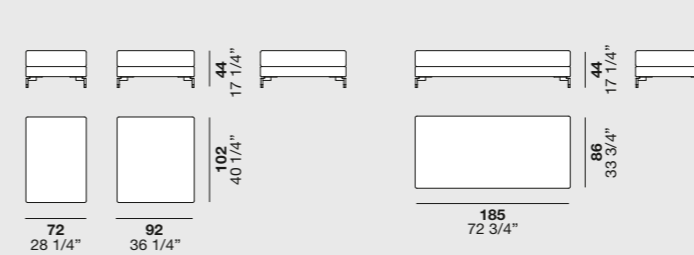

Chaise longue sx o dx

Left or Right facing chaise longue / Chaise longue izda. o dcha. / Chaise longue gauche ou droite / Chaiselongue li. oder re. / Лев. или прав. шезлонги

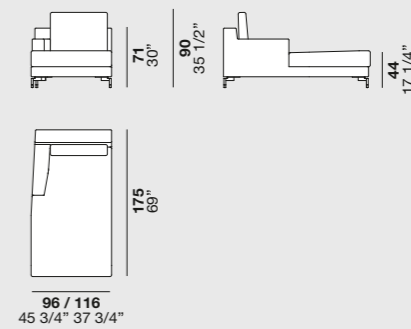



Esempi di composizioni
 Composition examples / Ejemplos de composiciones / Exemples de compositions /
 Beispiele für Zusammenstellungen / Примеры композиций

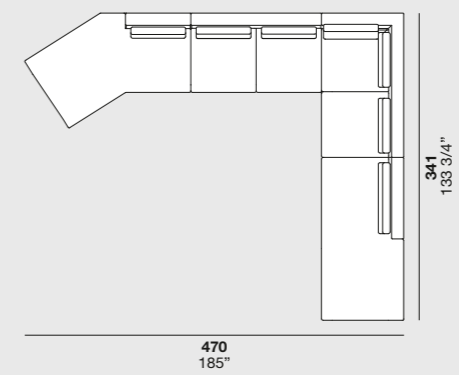
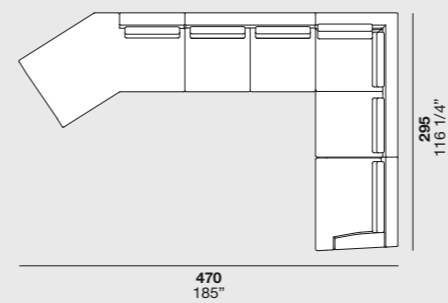
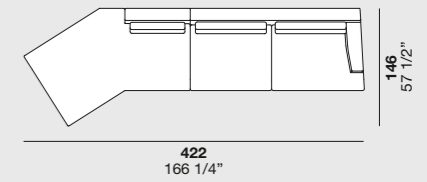
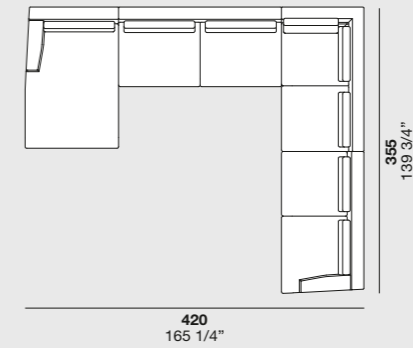
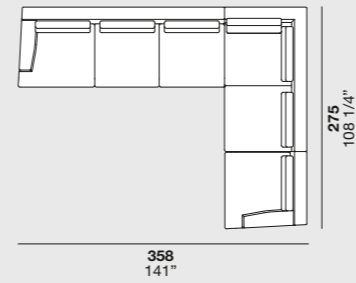
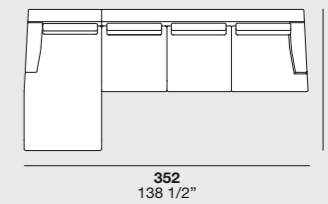
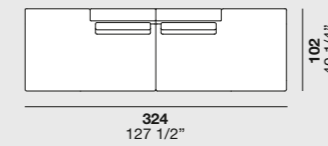
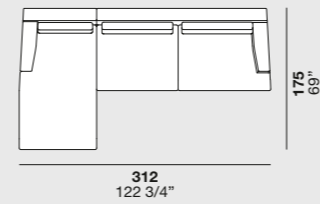
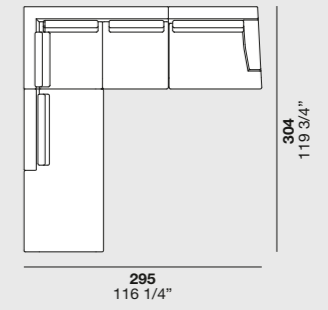
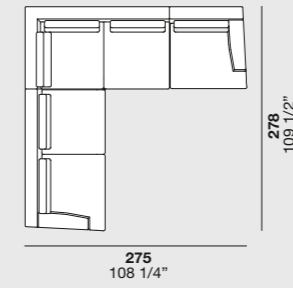
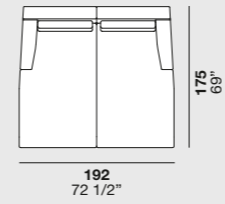

California

design **Enrico Cesana**



Materiali e finiture

Rivestimento:
Tessuti / Pelle / Ecopelle

Materials and finishes
Covering:
Fabric / Leather / Ecoleather

Materiales y acabados
Revestimiento:
Tejidos / Piel / Eco-piel

Matériaux et finitions
Revêtement :
Tissus / Cuir / Éco-cuir

Materialien und Ausführungen
Bezug:
Stoff / Leder / Kunstleder

Материалы и варианты отделки
Обивка:
Ткань / Кожа / Экокожа

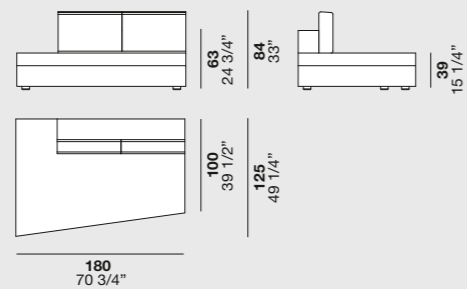
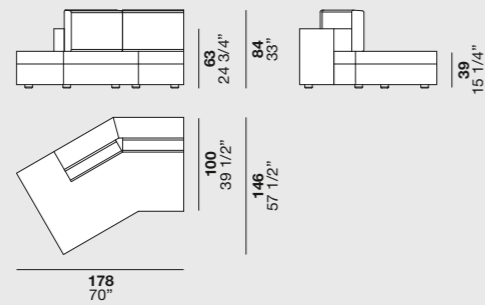

Esempi di composizioni

Composition examples / Ejemplos de composiciones / Exemples de compositions /
Beispiele für Zusammenstellungen / Примеры композиций

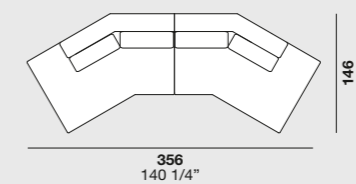
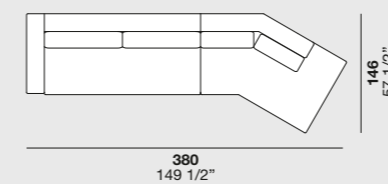
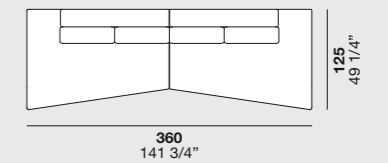
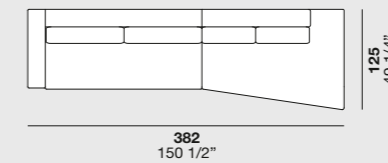
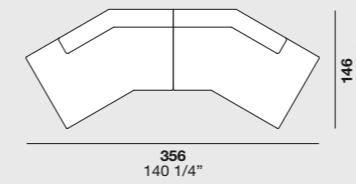
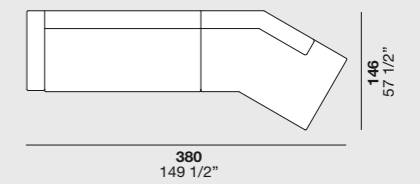
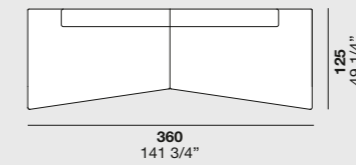
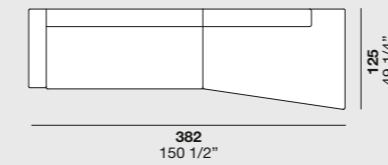

Copenhagen

design **Enrico Cesana**



Divani

Sofas / Sofás / Canapés / Sofas / Диваны

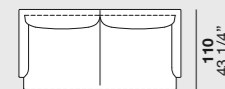
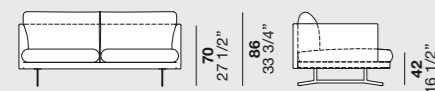

180 / 200 / 220 / 240 / 260
70 3/4" 78 3/4" 86 1/2"
94 1/2" 102 1/4"

Divani per angolo sx o dx

Left or Right facing sofas for corner / sofás para esquina izda. o dcha. / canapés pour coin gauche ou droit / Sofas für die li. oder re. / Ecke / диваны для левого или правого угла

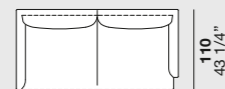
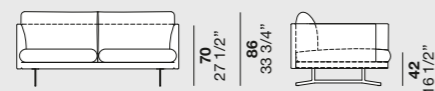

180 / 200 / 220 / 240 / 260
70 3/4" 78 3/4" 86 1/2"
94 1/2" 102 1/4"

Moduli terminali sx o dx

Left or Right facing end units / Módulos terminales izda. o dcha. / Modules terminaux gauches ou droits / Abschlusselemente li. oder re. / Терминальные лев. или прав. модули

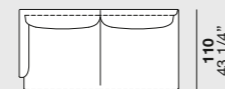
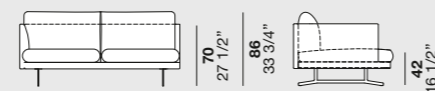

175 / 195 / 215 / 235 / 255
69" 76 3/4" 84 3/4"
92 1/2" 100 1/2"

Divani con cuscini decorativi

Sofas / Sofás / Canapés / Sofas / Диваны

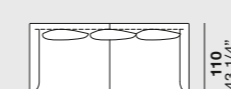

180 / 200 / 220 / 240 / 260
70 3/4" 78 3/4" 86 1/2"
94 1/2" 102 1/4"

Divani per angolo sx o dx

Left or Right facing sofas for corner / sofás para esquina izda. o dcha. / canapés pour coin gauche ou droit / Sofas für die li. oder re. / Ecke / диваны для левого или правого угла

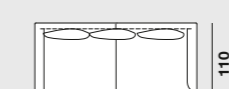

180 / 200 / 220 / 240 / 260
70 3/4" 78 3/4" 86 1/2"
94 1/2" 102 1/4"

Moduli terminali sx o dx

Left or Right facing end units / Módulos terminales izda. o dcha. / Modules terminaux gauches ou droits / Abschlusselemente li. oder re. / Терминальные лев. или прав. модули

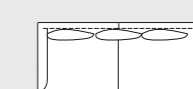

175 / 195 / 215 / 235 / 255
69" 76 3/4" 84 3/4"
92 1/2" 100 1/2"

Chaise longue sx o dx

Left or Right facing chaise longue / Chaise longue izda. o dcha. / Chaise longue gauche ou droite / Chaiselongue li. oder re. / Лев. или прав. шезлонги

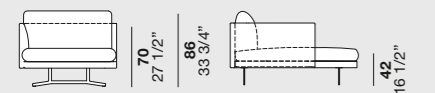

110
43 1/4"

Moduli penisola

Peninsula units / Módulos península / Modules péninsule / Halbinsel-Module / Полуостровные модули

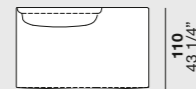

170
67"

Moduli centrali

Central units / Módulos centrales / Modules centraux / Mittelelemente / Центральные модули

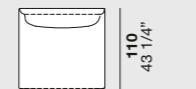
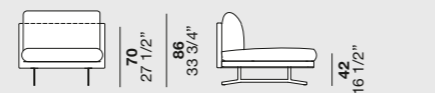

110
43 1/4"

Chaise longue sx o dx

Left or Right facing chaise longue / Chaise longue izda. o dcha. / Chaise longue gauche ou droite / Chaiselongue li. oder re. / Лев. или прав. шезлонги

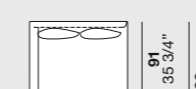
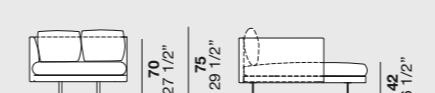

110
43 1/4"

Moduli penisola

Peninsula units / Módulos península / Modules péninsule / Halbinsel-Module / Полуостровные модули

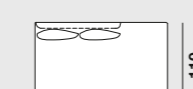

170
67"

Moduli centrali

Central units / Módulos centrales / Modules centraux / Mittelelemente / Центральные модули

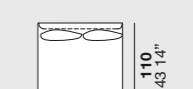
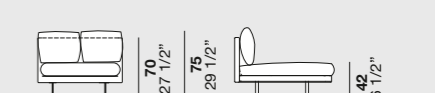

110
43 1/4"

Poltrone

Armchairs / Sillones / Fauteuil / Armlehnstühle / Кресла



150
59"

Pouf

Pouf / Puffs / Pouf / Polsterhocker / Пуфы

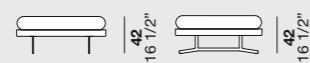

110
43 1/4"



Materiali e finiture

Rivestimento:
Tessuti / Pelle / Ecopelle
Gambe in metallo:
Verniciato Moka Shine /
Verniciato Rame brunito

Materials and finishes

Covering:
Fabric / Leather / Ecoleather
Metal legs:
Moka Shine Painted /
Rame brunito painted

Materiales y acabados

Revestimiento:
Tejidos / Piel / Eco-piel
Patas de metal:
Barnizado Moka Shine /
Barnizado rame brunito

Matériaux et finitions

Revêtement :
Tissus / Cuir / Éco-cuir
Pieds en métal :
Verni Moka Shine /
Verni rame brunito

Materialien und Ausführungen

Bezug:
Stoff / Leder / Kunstleder
Beinen aus Metall:
Lackiert Moka Shine / Brüniertes
und lackiertes Kupfer

Материалы и варианты отделки

Обивка:
Ткань / Кожа / Экокожа
Металлические ножки:
Крашенный Moka Shine /
Крашенный rame brunito

Esempi di composizioni

Composition examples / Ejemplos de composiciones / Exemples de compositions /
Beispiele für Zusammenstellungen / Примеры композиций

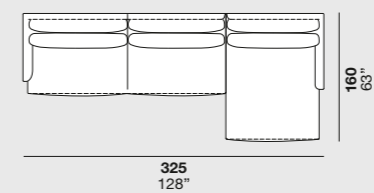
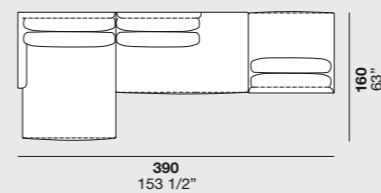
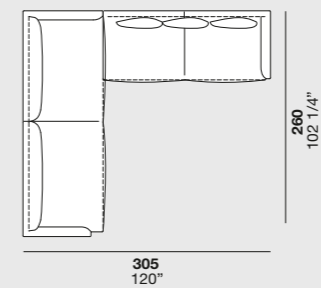
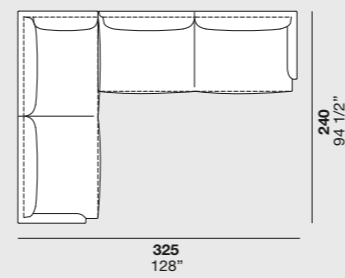

Fyra

design R.D.A.



Materiali e finiture

Gambe e piano:
Fashion wood / Rovere laccati opachi.
Staffe di collegamento in metallo:
Verniciato Moka Shine

Materials and finishes

Legs and top:
Fashion Wood / Matt lacquered oak
Metal brackets:
Painted Moka Shine

Materiales y acabados

Patas y sobre:
Fashion wood / Roble lacados mate
Soportes de unión de metal:
Barnizado Moka Shine

Matériaux et finitions

Pieds et plateau :
Fashion wood / Chêne laqués mats
Brides de raccordement en métal :
Verni Moka Shine

Materialien und Ausführungen

Beine und Platte:
Fashion Wood / Eiche matt lackiert
Verbindungswinkel aus Metall:
Lackiert Moka Shine

Материалы и варианты отделки

Ножки и столешница:
Fashion wood / Дуб крашенный матовый
Металлические соединительные кронштейны:
Крашенный Moka Shine

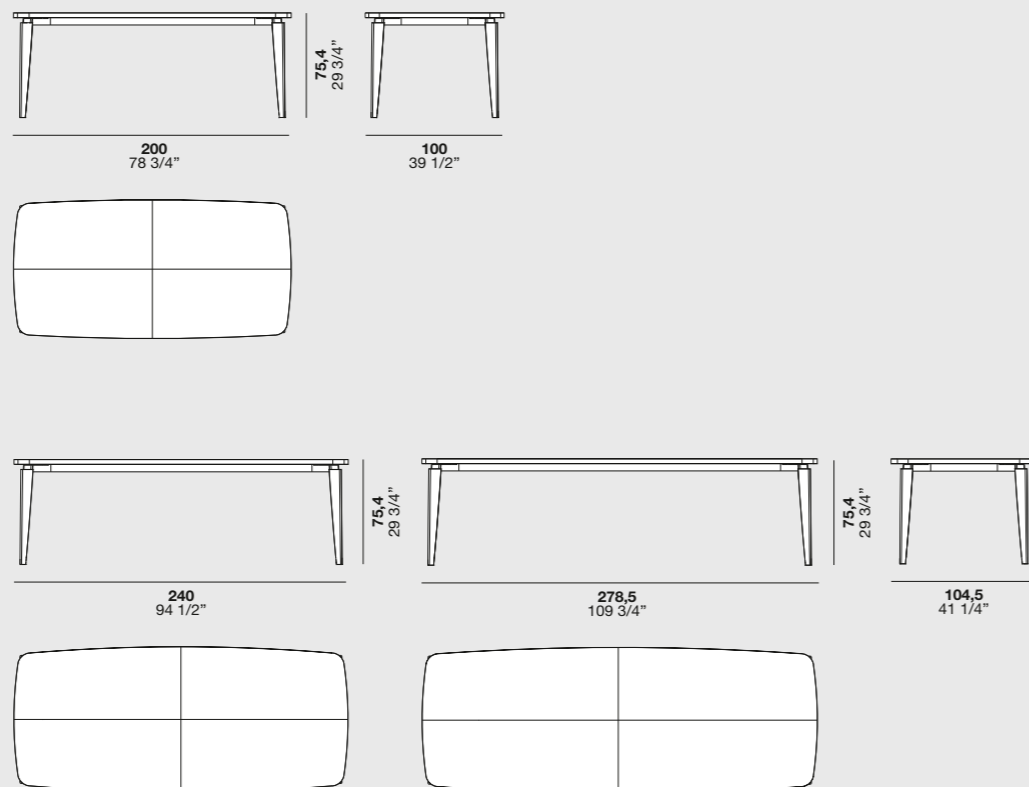

Neyō

design Gordon Guillaumier



Materiali e finiture

Struttura metallo:
Verniciato Moka Shine
Piano:
Fashion wood / Rovere laccati opachi /
Marmo di Carrara

Materials and finishes

Metal frame:
Painted Moka Shine
Top:
Fashion Wood / Matt lacquered oak /
Carrara marble

Materiales y acabados

Estructura de metal:
Barnizado Moka Shine
Sobre:
Fashion wood / Roble lacados mate /
Mármol de Carrara

Matériaux et finitions

Structure en métal :
Verni Moka Shine
Plateau :
Fashion wood / Chêne laqués mats /
Marbre de Carrara

Materialien und Ausführungen

Metallkorpus:
Lackiert Moka Shine
Platte:
Fashion Wood / Eiche matt lackiert /
Carrara-Marmor

Материалы и варианты отделки

Металлический каркас:
Крашенный Moka Shine
Столешница:
Fashion wood / Дуб крашенный матовый
/ Мрамор Carrara

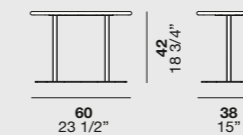

Neyō

design **Gordon Guillaumier**



Materiali e finiture

Testiera e piattaforma:
Tessuti / Pelle / Ecopelle
Comodini: Fashion wood / Rovere
laccati opachi / Marmo di Carrara
Piedi: metallo verniciato Moka Shine

Materials and finishes

Headboard and platform:
Fabric / Leather / Ecological leather
Bedside tables: Fashion Wood / Matt
lacquered oak / Carrara marble
Feet: Moka Shine painted metal

Materiales y acabados

Cabecera y plataforma:
Tejidos / Piel / Eco-piel
Mesitas de noche: Fashion wood /
Roble lacados mate / Mármol de Carrara
Patas: metal barnizado Moka Shine

Matériaux et finitions

Tête de lit et encadrement :
Tissus / Cuir / Éco-cuir
Chevets : Fashion wood / Chêne laqués
mats / Marbre de Carrara
Pieds : métal verni Moka Shine

Materialien und Ausführungen

Kopfteil und Liegefläche:
Stoff / Leder / Kunstleder
Nachttische: Fashion Wood / Eiche matt
lackiert / Carrara-Marmor
FüÙe: Metall lackiert Moka Shine

Материалы и варианты отделки

Головная спинка и платформа:
Ткань / Кожа / Экокожа
Тумбочки: Fashion wood / Дуб
крашеный матовый / Мрамор Carrara
Ножки: крашеный металл Moka Shine

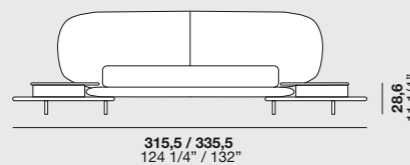
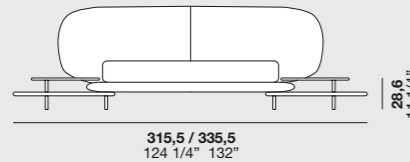
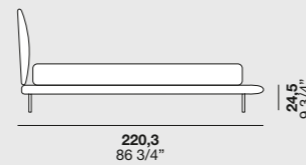
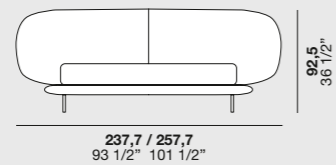

Jetty

design **Gordon Guillaumier**



Materiali e finiture

Struttura metallo:
finitura "elettrocol"
Testiera:
Tessuti / Pelle / Ecopelle

Materials and finishes

Metal frame:
Elettrocol finish
Headboard:
Fabric / Leather / Ecological leather

Materiales y acabados

Estructura de metal:
acabado "elettrocol"
Cabecera:
Tejidos / Piel / Eco-piel

Matériaux et finitions

Structure en métal :
finition « elettrocol »
Tête de lit :
Tissus / Cuir / Éco-cuir

Materialien und Ausführungen

Metallkorpus:
Ausführung „Elettrocol“
Kopfteil:
Stoff / Leder / Kunstleder

Материалы и варианты отделки

Металлический каркас:
отделка "elettrocol"
Головная спинка:
Ткань / Кожа / Экокожа

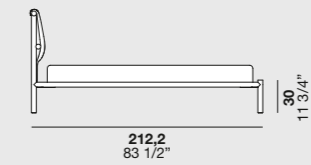
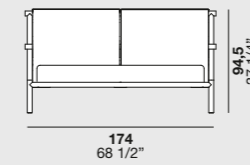

Relief

Collezioni tappeti / Rugs collection

Materiale: Viscosa.

Struttura: Tessuta a mano su telai artigianali.

Material: Viscose.

Frame: Woven by hand on a loom.



Sabbia



Terra



Pietra

ITALIER



www.italier.cz | info@italier.cz | +420 774 431 196