



ARREDOCLASSIC

Il prestigio del Made in Italy

ADORA
LUXURY-À-PORTER

SCHEMA DI MONTAGGIO ARMADIO 3/ ANTE
ASSEMBLING INSTRUCTION FOR 3/DOORS WARDROBE
INSTRUCTION DE MONTAGE ARMOIRE 3/PORTES
ИНСТРУКЦИИ ПО МОНТАЖУ ШКАФА 3/СТВОРКИ

— *Modigliani Collection* —





AVVERTENZA

Se il mobile si ribalta può causare lesioni da schiacciamento serie o fatali. Per prevenire il rischio che il mobile si ribalti, quest'ultimo deve essere fissato alla parete.

Gli accessori per il fissaggio alla parete non sono inclusi perché pareti di materiali diversi richiedono tipi diversi di accessori di fissaggio. Usa sistemi di fissaggio adatti alle pareti della tua casa.

WARNING

If the cabinet overturns it can cause serious or fatal crushing injuries. To prevent the risk of the furniture tipping over, it must be fixed to the wall.

Wall-mounting accessories are not included because walls of different materials require different types of fixing accessories. Use fixing systems suitable for the walls of your home.

ПРЕДУПРЕЖДЕНИЕ

Если мебель опрокидывается, это может привести к серьезным или смертельным ранениям. Чтобы предотвратить опасность опрокидывания мебели, ее необходимо зафиксировать на стене. Принадлежности для настенного монтажа не включаются, потому что стены из разных материалов требуют различных типов крепежных принадлежностей. Используйте крепежные системы, подходящие для стен вашего дома.

AVERTISSEMENT

Si le meuble se renverse, cela peut provoquer des blessures par écrasement graves ou mortelles. Pour éviter le risque de renversement des meubles, ceux-ci doivent être fixés au mur. Les accessoires de fixation murale ne sont pas inclus car les murs de différents matériaux nécessitent différents types d'accessoires de fixation. Utilisez des systèmes de fixation adaptés aux murs de votre maison.



PULIZIA E MANUTENZIONE

MOBILI

Per la pulizia di tutti i ns. mobili usare un panno di soffice cotone debitamente umidificato con una miscela di 50% acqua + 50% alcool etilico (uso disinfettante). Non usare mai il panno asciutto, poiché creerebbe dei micro graffi. Non usare prodotti aggressivi contenenti diluente, acetone o qualsiasi altro agente chimico. Può invece essere usato il "Vetril" su tutte le superfici, meglio spruzzato sul panno e non direttamente sulle parti verniciate.

CLEANING AND MAINTENANCE

FURNITURE

For the cleaning of all our furniture use a soft cotton cloth, duly moistened with a mixture of 50% water + 50% ethyl alcohol (disinfectant use). Never use a dry cloth as it will create micro scratches. Do not use aggressive products containing diluent, acetone or any other chemical ingredient. A glass cleaning product can be used on all surfaces: we advise to spray it on the cloth and not directly on the painted parts.

ЧИСТКА И ОБСЛУЖИВАНИЕ

КОРПУСНАЯ МЕБЕЛЬ

Для очистки всей нашей мебели используйте ткань из мягкого хлопка, должным образом увлажненную смесью 50% воды + 50% спирта этилового (используя его как дезинфицирующее средство). Никогда не пользуйтесь сухой тканью, так как остаются в таком случае микро-царапины. Не используйте агрессивные продукты, содержащие растворитель, ацетон или любое другое химическое вещество. Вместо этого может быть использован "ветрил" на всех поверхностях, лучше распылять его сначала на ткань, а не непосредственно на окрашенные поверхности.

NETTOYAGE ET MANUTENTION

MEUBLES

Pour le nettoyage de tous nos meubles utilisez un chiffon en coton doux dûment humidifié avec un mélange de 50% d'eau + 50% d'alcool éthylique (utilisation de désinfectant). N'utilisez jamais le chiffon sec car cela créerait des micro-rayures. N'utilisez pas de produits agressifs contenant du diluant, de l'acétone ou tout autre agent chimique. Plutôt, un produit de nettoyage de verre peut être utilisé sur toutes les surfaces; il faudrait l'asperger sur le tissu et non directement sur les parties peintes.

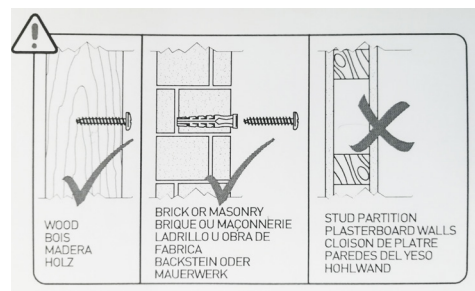

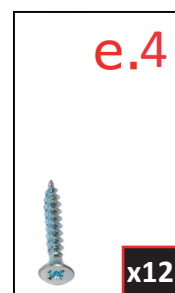
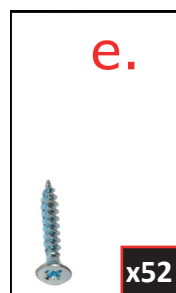
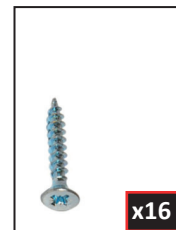
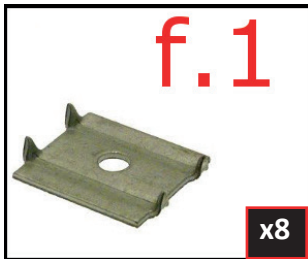
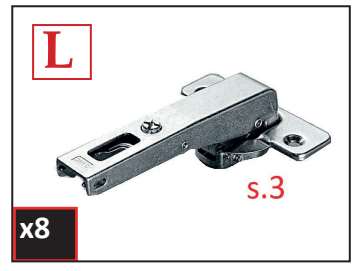
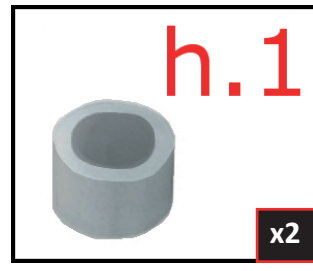
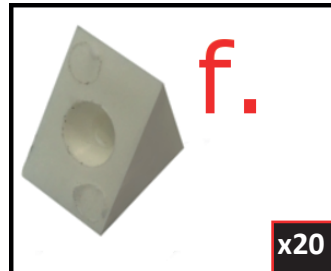
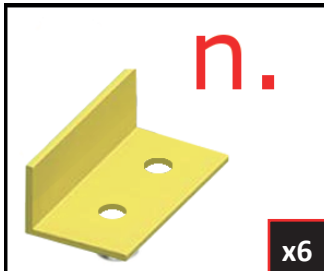
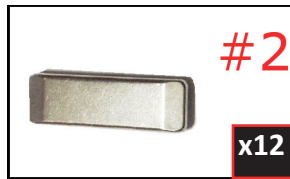

1

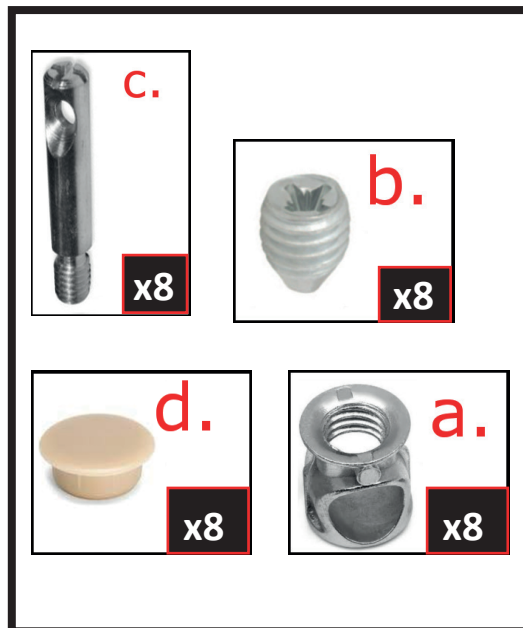
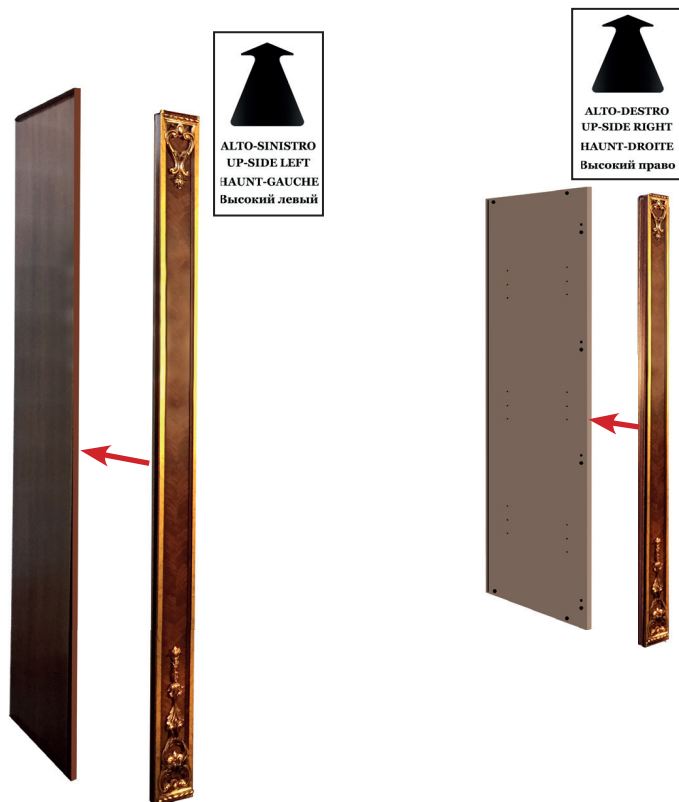

2

A

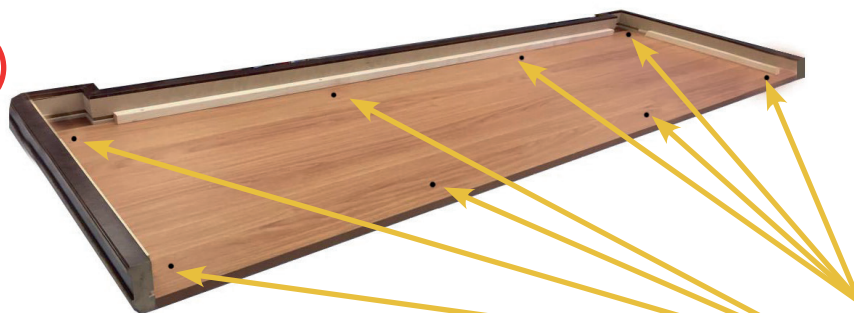

2

B

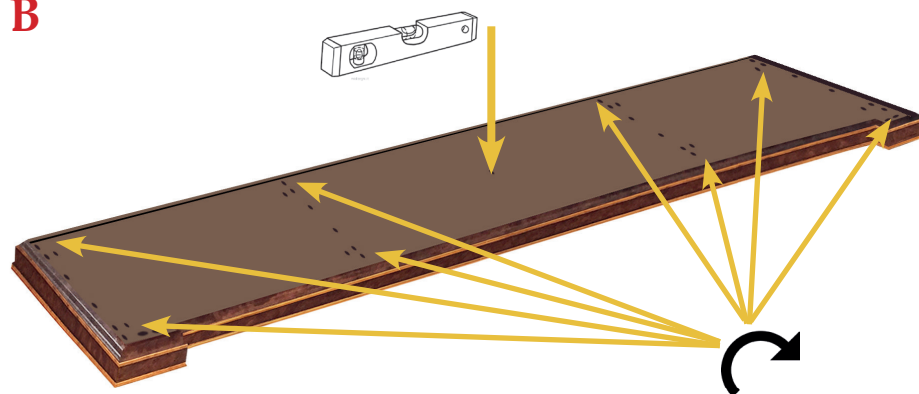

3

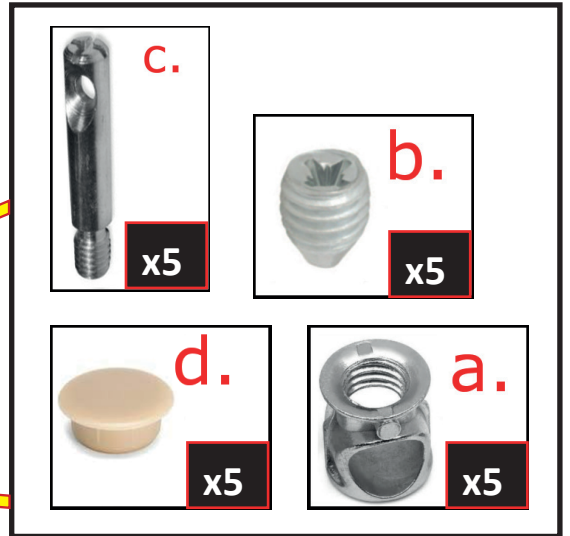

4

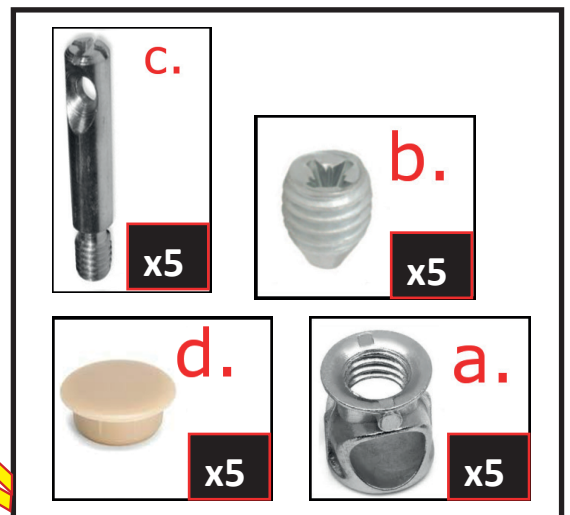
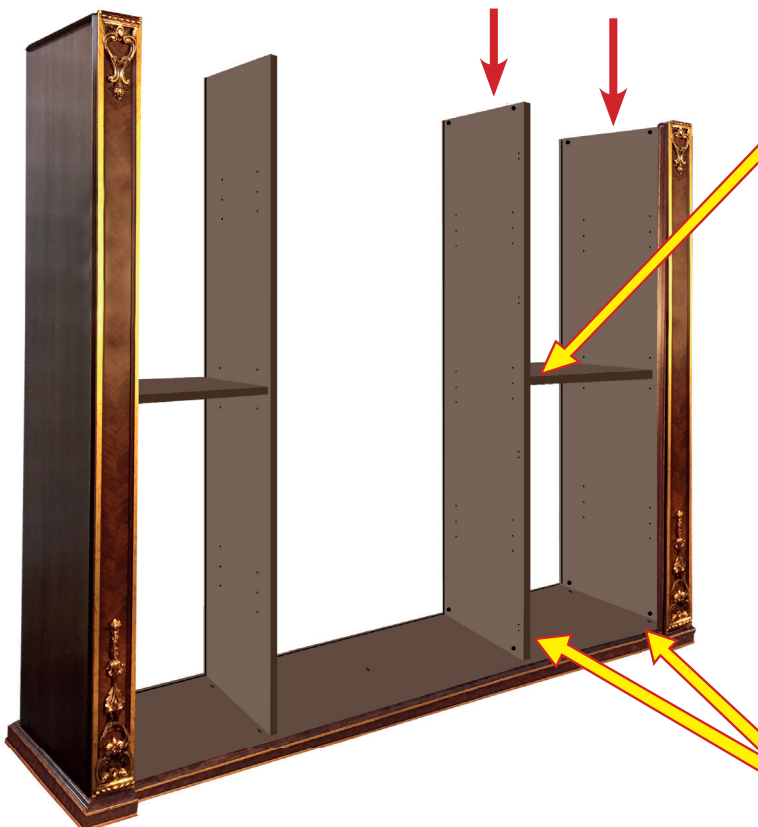



ARREDOCLASSIC

Il prestigio del Made in Italy

ADORA
LUXURY-A-PORTER

SCHEMA DI MONTAGGIO ARMADIO 3/ANTE
ASSEMBLING INSTRUCTION FOR 3/DOORS WARDROBE
INSTRUCTION DE MONTAGE ARMOIRE 3/PORTES
ИНСТРУКЦИИ ПО МОНТАЖУ ШКАФА 3/СТВОРКИ

— Modigliani Collection —

5

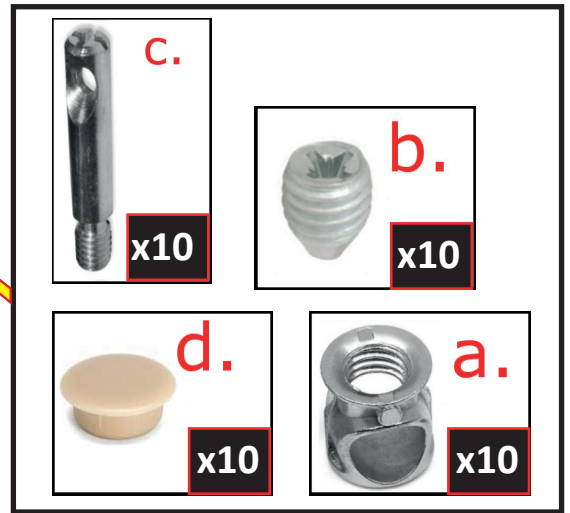

6

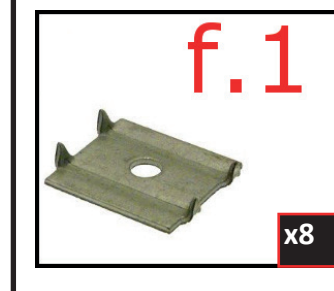
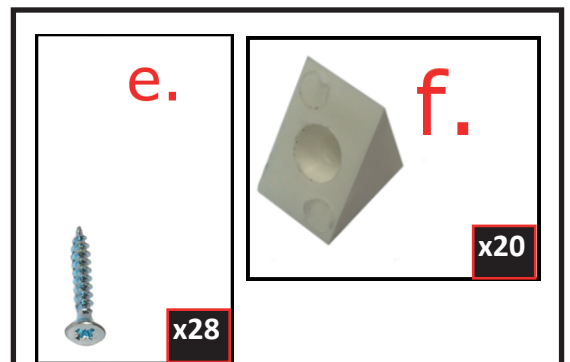

7



8

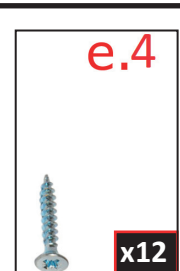
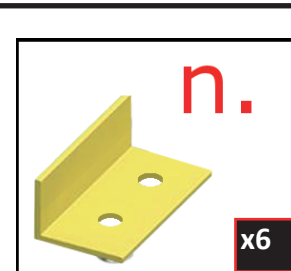

9

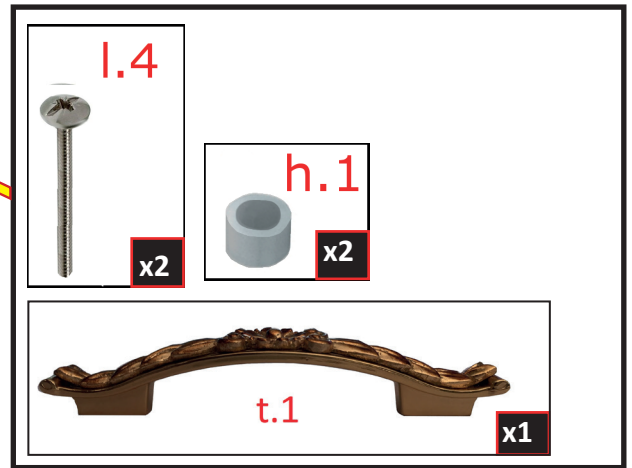
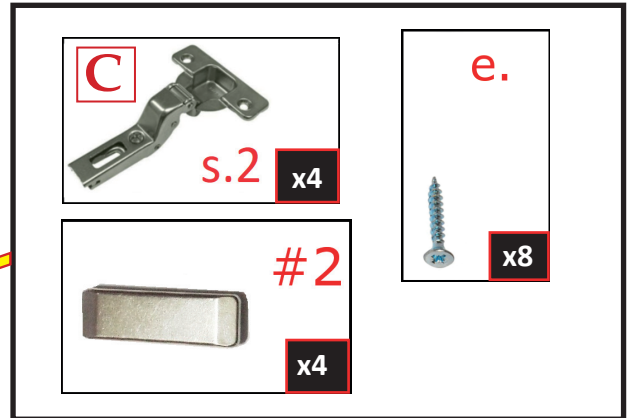

10

